

# Laser Spectrum Requirements for Tight CD Control at Advanced Logic Technology Nodes

R. C. Peng\*<sup>a</sup>, H. J. Lee<sup>a</sup>, John Lin<sup>a</sup>, Arthur Lin<sup>b</sup>, Allen Chang<sup>c</sup>, and Benjamin Szu-Min Lin<sup>c</sup>  
<sup>a</sup>MTC, Taiwan Semiconductor Manufacturing Corp., Hsinchu Science Park, Hsinchu, Taiwan 300-77, R.O.C.; <sup>b</sup>KLA-Tencor Corp., Chupei City, Hsinchu, Taiwan, R.O.C.; <sup>c</sup>Cymer Inc., Kuang Fu Rd. HsinChu, Taiwan, R.O.C.

## ABSTRACT

Tight circuit CD control in a photolithographic process has become increasingly critical particularly for advanced process nodes below 32nm, not only because of its impact on device performance but also because the CD control requirements are approaching the limits of measurement capability. Process stability relies on tight control of every factor which may impact the photolithographic performance. The variation of circuit CD depends on many factors, for example, CD uniformity on reticles, focus and dose errors, lens aberrations, partial coherence variation, photoresist performance and changes in laser spectrum. Laser bandwidth and illumination partial coherence are two significant contributors to the proximity CD portion of the scanner CD budget. It has been reported that bandwidth can contribute to as much as 9% of the available CD budget, which is equivalent to ~0.5nm at the 32nm node. In this paper, we are going to focus on the contributions of key laser parameters e.g. spectral shape and bandwidth, on circuit CD variation for an advanced node logic device. These key laser parameters will be input into the photolithography simulator, Prolith, to calculate their impacts on circuit CD variation. Stable through-pitch proximity behavior is one of the critical topics for foundry products, and will also be described in the paper.

**Keywords:** CD control, laser parameter, laser spectrum, photolithography simulation

## 1. INTRODUCTION

As critical dimension (CD) is shrunk following Moore's Law, tight circuit CD control becomes more and more difficult, because of not only the reduced CD tolerance, but also hitting the equipment control limitations and CD measurement limitations. There are many factors that impact CD variations, for example, CD uniformity on reticles, focus errors, lens aberrations, partial coherence variation, photoresist performance and laser spectrum. Laser bandwidth and illumination partial coherence are two of the largest contributors to the proximity CD portion of the scanner CD budget, in the other words, Iso-Dense Bias (IDB) or through-pitch performance. IDB performance can be attributed to numerous factors that generate changes in image contrast or induce focus blur, for examples, illumination condition adjustment and laser light source spectral bandwidth (E95%). These factors are necessary to be controlled to fully compensate for IDB variation to the level required at advanced process nodes.<sup>[1]-[5]</sup>

In previous studies, the sensitivity of IDB and through-pitch performance with regards to laser spectral bandwidth were reported for both 45nm Node logic device<sup>[6]</sup> and 32nm Node logic device.<sup>[7]</sup> These results showed that for IDB change of 1nm, E95% variation needs to be controlled to 69fm and 45fm, for 45nm and 32nm logic devices respectively. Increasingly higher spectral bandwidth stability is required for each successive technology node. This indicates that the 22nm Node will demand even tighter bandwidth stability and the added ability to set spectral bandwidth with both high accuracy and flexibility.

Factors from light sources impacting product yields can be divided into two groups, CD control and overlay. Figure 1 shows the laser parameters that contribute to CD control and overlay. Contrast and intensity are two key factors that impact CD control. With further breaking down, the key laser parameters contributing CD control are bandwidth, spectral shape, ASE, wavelength stability, beam stability, energy stability, laser coherence and polarization. In this manuscript, the effects of laser parameters, specifically bandwidth and spectral shape, on CD control will be discussed.



Figure 1. The key laser parameters contributing to product yield (CD control + overlay).

## 2. SIMULATION CONDITIONS

Figure 2 illustrates the flow chart used for simulation. An L/S layer from an advanced node logic device was chosen as the target layout for this simulation work. Through-pitch 1-D L/S patterns from the minimum pitch to full isolated features were simulated. No sub-resolution assistant features (SRAFs) were used, but only mask biases were applied to compensate the optical proximity effects at a certain chosen laser condition. Original through-pitch 1-D L/S patterns and illumination conditions (193nm Immersion + Dipole illumination + Y-Polarization + Att. PSM) were the 1<sup>st</sup> set of input parameters to calculate the Eop to meet the nominal target CD size for the feature with the minimum pitch and then calculate mask biases for all the other features. Prolith version Ver. X3 was used for all the simulation work in this manuscript. Only aerial image CDs were taken into account for simplifying the simulation work. Varied laser parameters, including E95, were used as the 2<sup>nd</sup> set of input parameters to check through-pitch DOF (@ 5% exposure latitude), proximity CDs, and CDU. Sigma fine-tuning was the 3<sup>rd</sup> set of input parameters to improve DOF at the forbidden pitches; optimum center sigma and radius sigma values were selected to achieve enough process margins for those forbidden pitches. Laser requirements were then derived from simulated CD results, and E95 CD sensitivity to meet the target CD/CDU criteria.

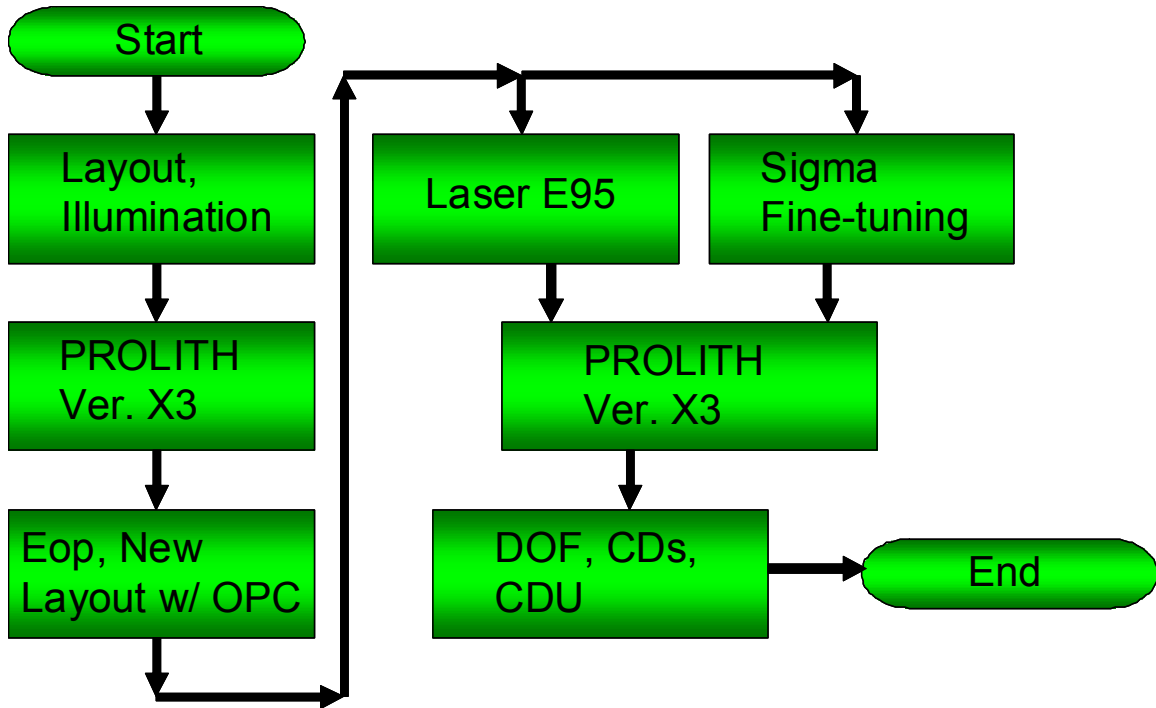

Figure 2. Simulation Flow Chart.

### 3. RESULTS AND DISCUSSIONS

#### 3.1 DOF and CDU

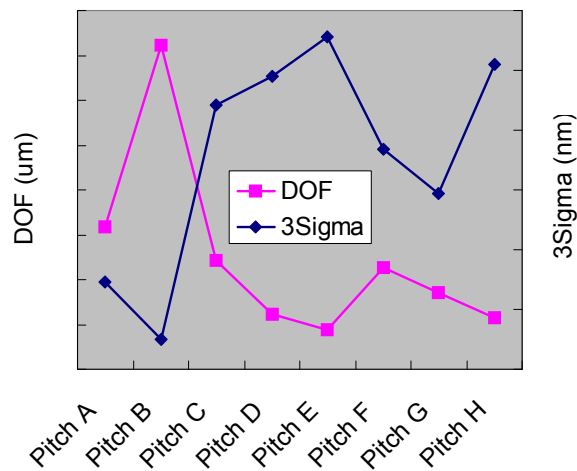

Figure 3. The through-pitch simulation results of DOF and CDU with assigned illumination conditions and built-in Cymer XLA light source parameters. The square line represents the through-pitch DOF trend while the diamond line the through-pitch CDU trend.

Figure 3 illustrates the through-pitch simulation results of DOF and CDU with assigned illumination conditions and built-in Cymer XLA300 light source parameters. The square line represents the through-pitch DOF trend while the diamond line the through-pitch CDU trend. No SRAFs were added but optimal mask biases were applied to through-pitch 1-D L/S patterns to compensate the OPC effects. Dipole illumination enhances the DOF and CDU values at the tighter pitches, however, the forbidden pitches (Pitch D and E) and isolated (Pitch H) L/S features show less DOF and expectedly worse CDU. It was believed that SRAFs could definitely enhance DOF and CDU for those isolated features, but would not improve DOF and CDU for the forbidden-pitch features because of insufficient space to insert any SRAF, under the reticle manufacturability constraints. Under the current illumination conditions and process settings, CD variations at forbidden pitches should be considered as the worst cases instead of CD behaviors at isolated features as usual due to their narrower process margins.

### 3.2 Bandwidth CD Dependency

Figure 4 shows the proximity curves in terms of CD differences exposed at different Cymer XLA laser bandwidths. E95%, instead of FWHM (full-width-half-maximum, default tunable parameter in Prolith Ver. X3), was used to represent the laser bandwidth changes here. The simulated E95% range in this study is from 355fm to 555fm. Proximity CD difference curve at an E95% of 435fm is flat because the through-pitch optimal mask biases were calculated at this condition. Based on the same mask bias settings, proximity CD difference curves for different E95% values were then calculated. Larger proximity CD difference variations occur as E95% is changed for the forbidden-pitches (Pitch D and E) and isolated (Pitch H) patterns. Even without SRAF, the proximity CD difference variation as a function of E95% at Pitch E is higher than that at isolated patterns. This indicates that forbidden-dense bias (FDB) may be a more relevant measure of bandwidth sensitivity than isolated-dense bias (IDB).

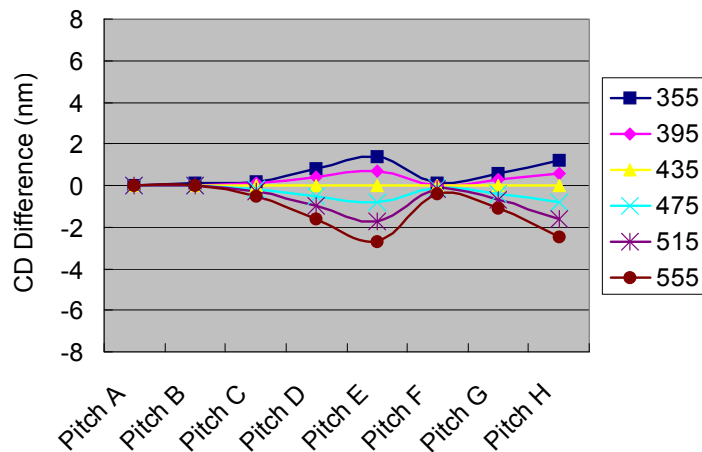

Figure 4. The proximity curves in terms of CD differences exposed at different Cymer XLA laser bandwidths. E95%, ranged from 355fm to 555fm, instead of FWHM (full-width-half-maximum, default tuning parameter in Prolith Ver. X3) and was used to indicate the laser bandwidth here. Proximity CD difference curve under E95% of 435fm is flat because the through-pitch optimal mask biases was calculated at this condition.

The E95% CD sensitivities of different pitches in the E95% range from 355fm to 555fm were calculated in Figure 5. The range of E95% - CD sensitivities is from 0.23nm/100fm to 2.04nm/100fm. The CD variation is derived as 0.09nm ~ 0.81nm based on typical Cymer XLA performance resulting in E95% 3 sigma of 40fm without active bandwidth control. In this case, CD variation can be improved down to 0.05nm ~ 0.47nm by Cymer new XLR platform, which features advanced bandwidth stabilization (ABS) technology, with typical long term E95% stability of 3 sigma of 23fm as shown in Figure 6. Pitch C and Pitch F patterns have the lowest E95% CD sensitivities of 0.35nm/100fm and 0.23nm/100fm, respectively. The highest E95% CD sensitivity occurs at forbidden pitch (Pitch E), while the 2<sup>nd</sup> highest E95% CD sensitivity occurs for isolated (Pitch H) patterns. If SRAF can be optimally implemented for isolated patterns and use of patterns with forbidden pitch (Pitch E) is restricted, the maximum E95% CD sensitivity can be improved by 42% (from

2.04nm/100fm to 1.19nm/100fm), which means 0.27nm CD variation under typical performance of Cymer's XLR platform long term stability of 23 fm E95%.

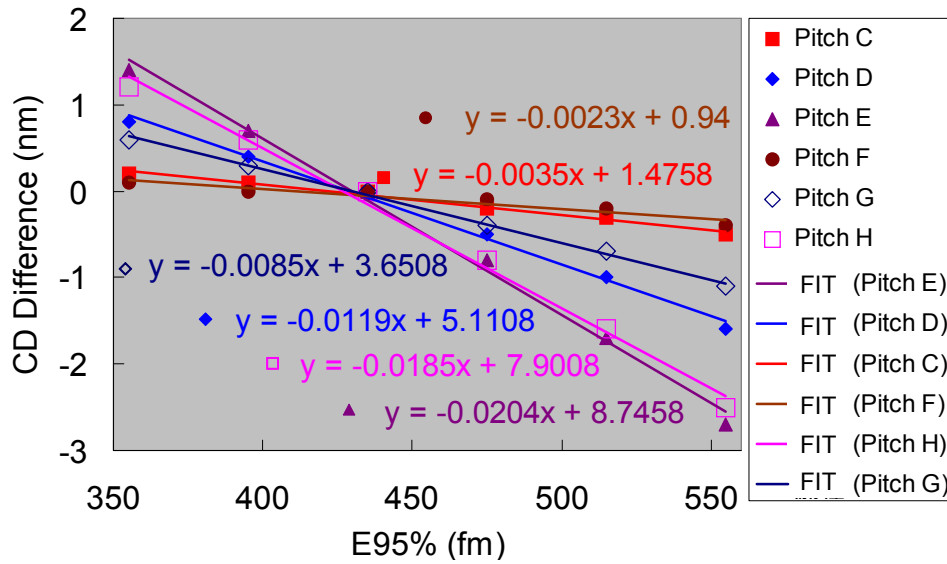

Figure 5. The E95% CD sensitivities of different pitches in the E95% range from 355fm to 555fm were calculated. The range of E95% CD sensitivities are from 0.23nm/100fm to 2.04nm/100fm.

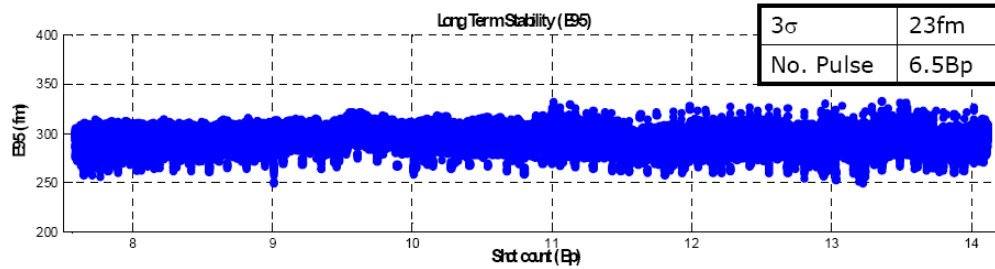

Figure 6. Typical long term E95% stability (3 sigma of 23fm) of Cymer new XLR platform with pulse numbers over 6 Bp. CD variation can be further improved as 0.05nm ~ 0.47nm by this Cymer new XLR platform.

### Spectral Shape Effects

Besides Cymer XLA300 spectrum as a built-in light source spectrum in Prolith for accurate simulation, a Lorentzian spectrum is also available for parametric and fast simulation. However, Lorentzian spectral shape looks very different from the Cymer XLA300 spectral shape. Power law coefficient (PLC) in Prolith Ver. X3 is therefore created to vary the Lorentzian spectral shapes into what is referred to as modified Lorentzian. Figure 7 demonstrates the spectral shapes of (a) Lorentzian spectral shape with PLC=1, (b) Lorentzian spectral shape with PLC=2, and (c) Cymer XLA300 spectral shape. It is obvious that the peak of the modified Lorentzian shape becomes rounded and the tails are suppressed as PLC increases from 1 to 2, which result in the modified Lorentzian spectral shape more closely fitting the Cymer XLA300 spectral shape. The effects of using the modified Lorentzian or Gaussian analytic approximations to actual laser spectra were also discussed previously.[8]

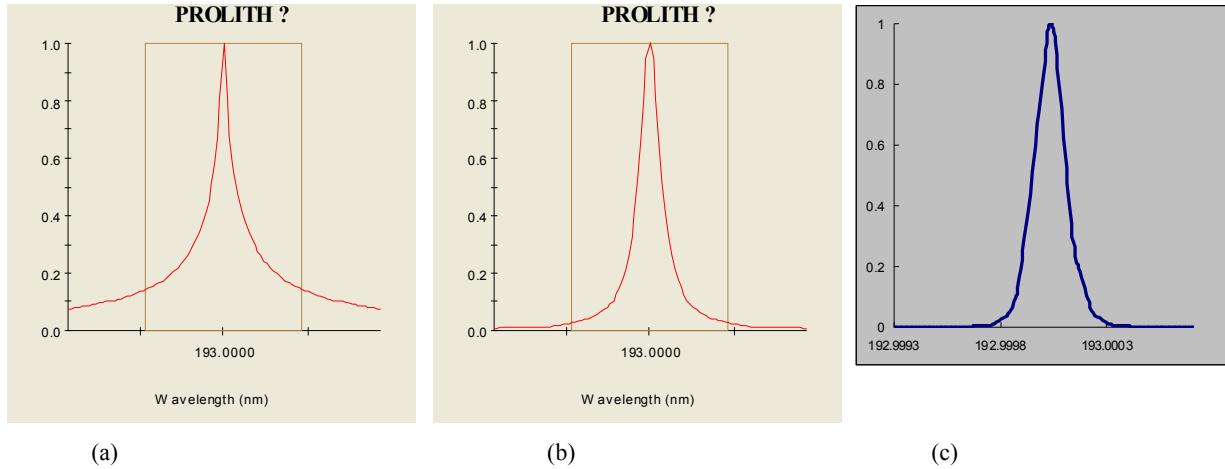

Figure 7. The spectral shapes of (a) Lorentzian spectral shape with PLC=1, (b) Lorentzian spectral shape with PLC=2, and (c) Cymer XLA300 spectral shape.

The proximity curves, in terms of their CD differences, can be drawn in Figure 8(a) and Figure 8(b) with Lorentzian spectral shape with PLC=1 and Lorentzian spectral shape with PLC=2, respectively. CD differences of the case of PLC=1 is apparently higher than that of the case of Cymer XLA300, while CD differences of the case of PLC=2 is much closer to the case of Cymer XLA300. Even though, bandwidth CD sensitivity of the case of PLC=2 is calculated as 2.8nm/100fm, which is about 40% larger than bandwidth CD sensitivity of Cymer XLA300 as 2.04nm/100fm.

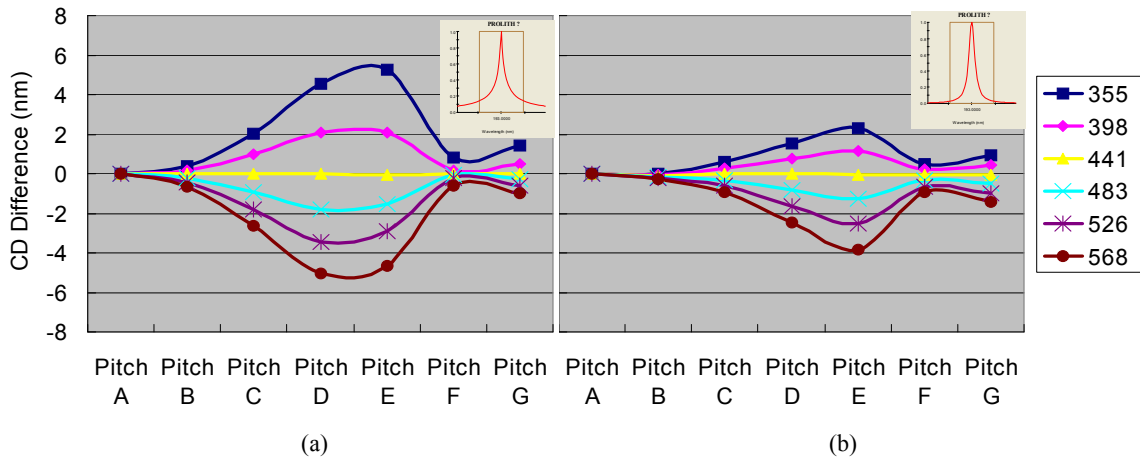

Figure 8. The proximity curves in terms of CD differences with (a) Lorentzian spectral shape with PLC=1 and (b) Lorentzian spectral shape with PLC=2.

In order to matching modified Lorentzian spectral shapes and actual Cymer XLA300 spectral shape more closely, modified Lorentzian spectra with higher PLCs were studied. From the log scale overlapping spectral chart (Figure 9), it can be told that modified Lorentzian spectral shape with PLC=4 matches actual Cymer XLA spectral shape, except those low level noises at the actual spectral footings.

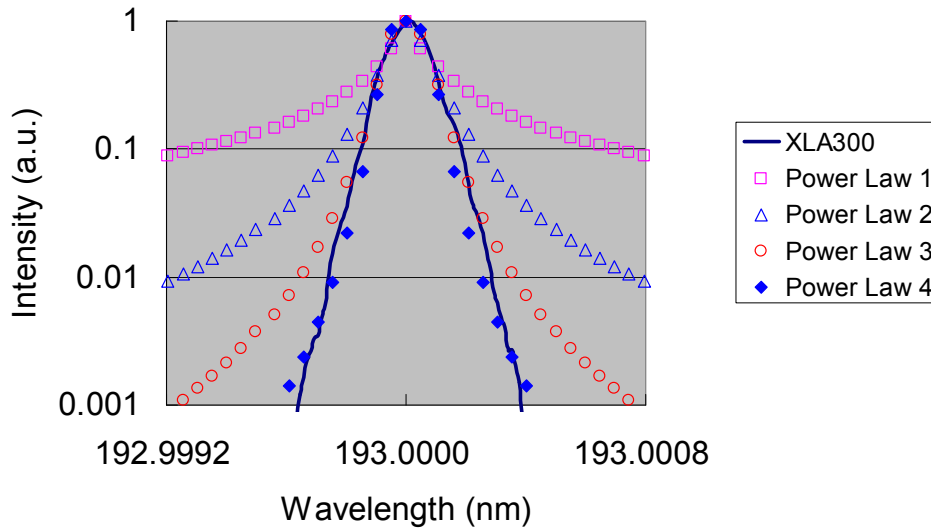

Figure 9. Lorentzian spectral shapes with PLC from 1 to 4 overlapped with actual Cymer XLA300 spectral shape.

### Illumination Optimization

Illumination optimization is a common and well-known way to improve DOF and CD variation of the forbidden-pitch patterns. However, it will suffer the process margin loss for those patterns with tighter pitches. Table 1 shows the relative DOF values (100% DOF @ Pitch E pattern under dipole center of 0.9 and dipole radius of 0.05) at different dipole center sigma and radius sigma combinations for Pitch A and Pitch E patterns. Dipole illumination generally favors tighter pitches and any off-optimal condition will result in a reduction of dense pattern process margins. Table 1(a) shows relative DOF values for Pitch A patterns, and the maximum DOF value occurs at the condition of dipole center of 0.8 and dipole radius of 0.05. Although DOF for Pitch E patterns, shown in Table 1(b), also achieves the maximum value under the Pitch A preferred condition, it may soon drop to zero if dipole center or dipole radius shifts to a lower value. In order to improve the process control margins, suggested dipole conditions could be (1) dipole center of 0.85 and dipole radius of 0.1 and (2) dipole center of 0.85 and dipole radius of 0.05, depending on the controllability of dipole center and dipole radius.

DOF	Dipole Radius Sigma				DOF	Dipole Radius Sigma			
Dipole Center Sigma	0.05	0.1	0.15	0.2	Dipole Center Sigma	0.05	0.1	0.15	0.2
0.6	133%	170%	146%	212%	0.6	0%	0%	0%	127%
0.65	201%	211%	272%	399%	0.65	0%	0%	0%	0%
0.7	323%	373%	497%	505%	0.7	0%	0%	0%	0%
0.75	836%	972%	715%	507%	0.75	0%	0%	0%	0%
0.8	1596%	943%	684%	485%	0.8	204%	0%	0%	0%
0.85	632%	845%	671%	520%	0.85	145%	153%	154%	0%
0.9	266%	296%	439%	515%	0.9	100%	119%	126%	135%

Table 1. The relative DOF values (100% DOF @ Pitch E pattern under dipole center of 0.9 and dipole radius of 0.05) at different dipole center sigma and radius sigma combination for (a) Pitch A and (b) Pitch E patterns.

## 4. CONCLUSION

In this manuscript, key laser light source parameters, e.g. bandwidth and spectral shape, have been studied to determine their contributions to CD variation and proximity variation. E95% forbidden-dense bias (FDB) should be characterized in addition to the usual IDB, because FDB has a higher E95% CD sensitivity due to the narrower process margins. Bandwidth dependent CD variation of 0.47nm for the advanced node logic device can be achieved with typical Cymer XLR long term E95% bandwidth performance of 3 sigma of 23fm, which is enabled by advanced bandwidth stabilization and control technologies. Bandwidth dependent CD variation can be further improved down to 0.27nm by adding SRAFs to isolated patterns and avoiding the use of the forbidden pitch (Pitch E in this case) in the pattern design. Illumination optimization can also increase DOF for those forbidden-pitch patterns, which can also improve E95% FDB sensitivity. In this study, we find that the Modified Lorentzian spectrum with PLC=4 can match the imaging results obtained using a Cymer XLA300 spectral shape at best focus.

## REFERENCE

- [1] M. Terry et al., “*Behavior of lens aberrations as a function of wavelength on KrF and ArF lithography scanners*”, Optical Microlithography XIV, SPIE 4346-41 p.15-24 (2001).
- [2] T. Brunner et al., “*Laser bandwidth and other sources of focus blur in lithography*”, Optical Microlithography XIX, SPIE 6154-31 (2006).
- [3] Kevin Huggins et al., “*Effects of laser bandwidth on OPE in a modern lithography tool*”, Optical Microlithography XIX, SPIE 6154-36 (2006).
- [4] Feder Trintchouk et al., “*XLA 300: the Forth-Generation ArF MOPA Light Source for Immersion Lithography*”, Optical Microlithography XIX, SPIE 6154-76 (2006).
- [5] T. Oga et al., “*Challenging to meet 1nm Iso- Dense Bias (IDB) by controlling Laser Spectrum*”, Advanced Lithography XXI, SPIE 6520-144 (2007).
- [6] K. Yoshimochi et al., “*45nm Node Logic Device OPE Matching between Exposure Tools Through Laser Bandwidth Tuning*”, Optical Microlithography XXI, SPIE 6924-92 (2008).
- [7] K. Yoshimochi et al., “*32nm Node Device Laser-bandwidth OPE Sensitivity and Process Matching*”, Optical Microlithography XXI, SPIE 7274-115 (2009).
- [8] Lalovic et al., “*Defining a physically-accurate laser bandwidth input for optical proximity correction (OPC) and modeling*”, Proc. BACUS XXII Photomask Technology Symposium 7122-62, (2008).