

Lithography Line Productivity Impact Using Cymer GLX™ Technology

Kevin O'Brien, Wayne J. Dunstan¹, Robert Jacques, Daniel Brown.
Cymer Inc., 17075 Thornmint Court, San Diego, CA, 92127, USA

ABSTRACT

Leading-edge scanners in fabs worldwide have particularly high system utilization and require peak levels of system throughput and availability. Laser gas exchanges typically occur daily on these systems (or every 100M pulses or less), with each exchange lasting up to 20 minutes. This downtime has a direct negative effect on availability, and if it is reduced, the productivity of the litho cell increases.

This paper will outline the immediate success fabs have experienced after equipping scanners with Cymer's Gas Lifetime eXtension (GLX™) technology, which increases scanner availability by extending the time between excimer laser gas exchanges by a factor of more than 10. To date, more than 100 leading-edge scanners feature Cymer's GLX technology, which has improved light source availability by more than 1.5 percent. Moreover, multiple chipmakers report more than 2 percent improvement in litho cell productivity due to GLX, corresponding to 2000 wafers/month increase for a 100,000 wafers/month fab. The increase in measured productivity is the leveraged benefit of reducing process interruptions around the refill cycle

GLX technology extends the shot-based interval between gas refills to 1 billion pulses for Cymer's XLA light sources, and provides excellent stability in key optical performance parameters, such as bandwidth and dose stability over the entire gas life. This paper will provide extensive performance data during extended light source operation on litho cells equipped with GLX technology, and multiple use scenarios will be examined, including usage at memory and logic fabs.

The paper will also discuss the performance of GLX2™ technology which further extends the maximum time between light source gas exchanges from 1B pulses to 2B pulses, and reduces downtime associated with gas refills by a factor of 20. The stability and productivity benefits of this new technology can be realized under all light source utilization scenarios. With GLX2, the refill interval at high utilization chipmakers is 3 weeks, and 4-8 weeks at lower utilization customers. Metrics illustrating the success of each of these capabilities will be presented. The second-generation of GLX technology was launched in July 2008 after chipmakers responded favorably to GLX performance metrics.

Keywords: laser, availability, gas, management, control

¹ wdunstan@cymer.com phone: int+1-858-385 6177, www.cymer.com

1. INTRODUCTION

The demand for high performance and high availability from advanced lithographic processes cascades down to many subsystems and components, including scanners and then to light sources. Leading light sources continue to successfully deliver high performance, and the development of availability improvements has been rapid in recent years. Chief among these has been the dramatic reduction of standby time due to Halogen gas refills.

The SEMI E10 standard (see reference 1), illustrated in Figure 1, defines downtime to include preventative maintenance and replacement of consumables, such as light source chambers and optics. The two “downtime” boxes denote the total time lost due to module replacement, while the “standby time” box indicates non-productive manufacturing time that includes Halogen gas refills.

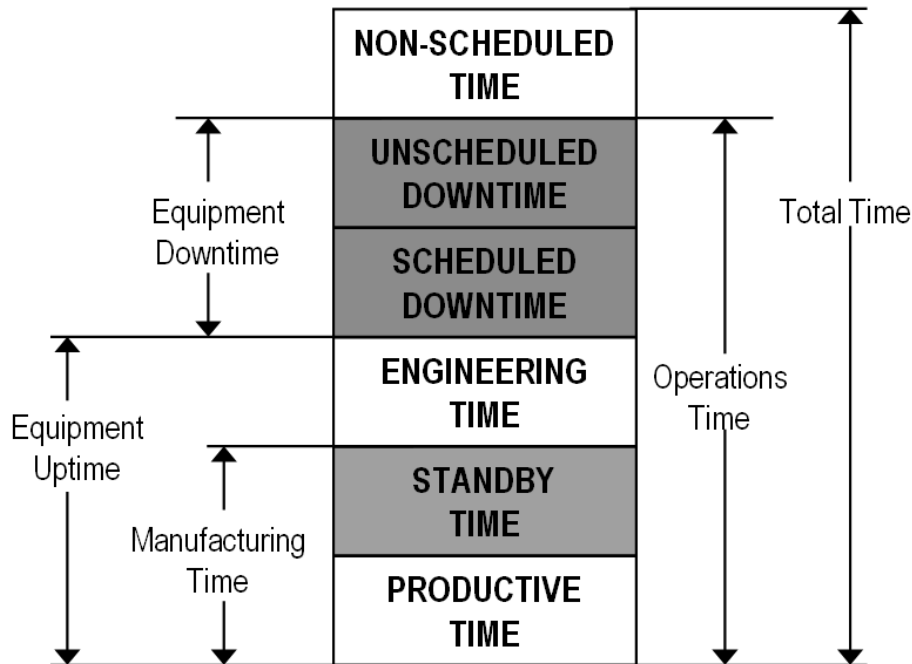

Figure 1: Breakdown of SEMI E10 standard (*Specification for Definition and Measurement of Equipment Reliability, Availability, and Maintainability*. See reference 1)

For systems with particularly high utilization, the standby time associated with Halogen gas refills has averaged previously up to 20 minutes per day (or per 100 Mpulses) on ArF systems (KrF systems have a longer interval). Understanding the impact of this to availability, Cymer researched and developed Gas Lifetime eXtension™ (GLX™) gas control technology. The result yielded an average Halogen gas replenishment standby time of 2 minutes per day (or 20 minutes per 1 Bpulses), a factor of 10 improvement. Additionally, GLX and GLX2 both increase the need for time-based refills significantly, from 3 days to well over 30 days in most circumstances.

Initial deployment of GLX to chipmakers on XLA (ArF) lines provided an immediate increase in availability of targeted light sources, as previously reported (reference 5). Thereafter, rapid adoption by high utilization chipmakers yielded measurable productivity increases. The positive response spurred Cymer to quickly develop and release GLX2™ technology, which provides a 20X improvement in standby time, down to 1 minute per day (or 20 minutes per 2 Bpulses) on average.

Moreover, GLX and GLX2 technologies provide excellent stability in key optical performance metrics such as bandwidth and dose stability, and do not impact module lifetimes, indicating that light source performance was not compromised. The gains in availability can be realized under multiple usage scenarios, such as memory and logic fabrication. Similar performance is also being observed with GLX on development systems of Cymer’s 7000 KrF line.

This paper describes GLX technology briefly, provides performance data for multiple usage scenarios, and reports on realized availability gains at chipmakers compared to predicted gains. Performance of GLX2 technology will also be provided.

2. DESCRIPTION OF GLX™ CONTROL SYSTEM

Cymer lasers employ one or more halogen gas filled chambers as the gain medium. During operation, depletion of the halogen gas and accumulated contaminants reduce efficiency, thereby increasing the drive voltage necessary to maintain desired energy, eventually reaching an upper limit. Therefore, the gas must be replenished and contaminants removed.

Gas replenishment and contaminant removal can be performed partially or completely. Although complete replenishment – called a refill – yields a fully replenished and contaminant-free chamber, it requires cessation of light source operation for up to 20 minutes, interrupting the lithography process. Therefore, Cymer targeted the reduction of refills (or the increase in time between refills) for what was to become GLX technology (see reference 4).

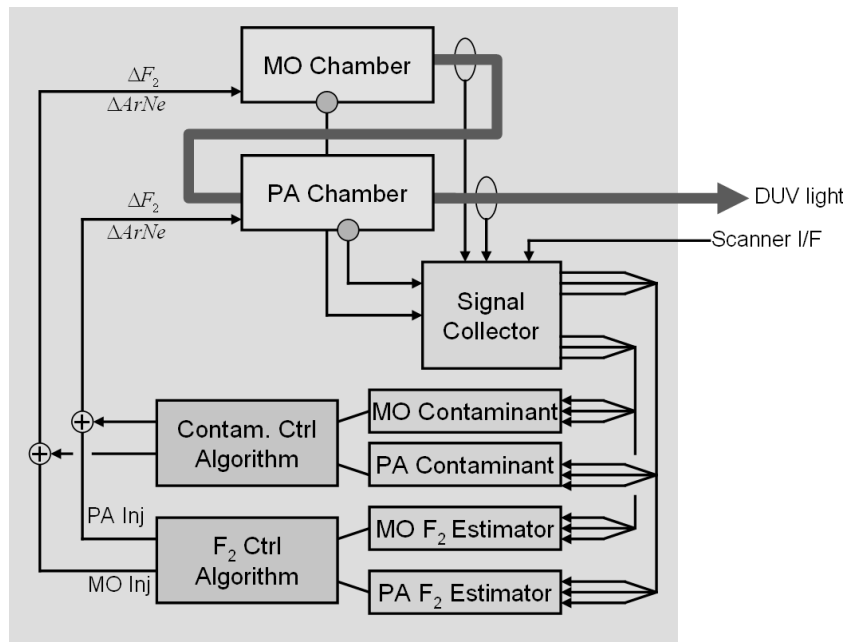

Figure 2: GLX Control System.

The reduction of refills in GLX was achieved through improvements in many technologies, including a new and better use of the partial replenishments called injects, cleaner discharge chambers, advanced signal processing and control algorithms (see references 2 and 3), and longer-life hardware. Reference 5 provides additional details. Not only does this increase the number of laser pulses between refills, but the light source can also operate well across long periods of non-firing time – one continuous month – without a refill.

GLX technology includes both contaminant and halogen gas control. Figure 2 from reference 5 shows that the algorithm estimates halogen (F_2) and contaminant contributions to laser performance from various signals gathered from light source operation, through signal processing. The control algorithm, which includes models of light source dynamics based on current and past usage, advanced estimation techniques, and additional signal processing, decides the quantity and timing of injects.

3. GLX™ PERFORMANCE

GLX and GLX2 technologies have been deployed on about 200 Cymer XL light sources throughout the world.² Although the primary end user has been memory makers, some logic makers have used GLX technology as well. With this increasing deployment, the opportunity is available to measure more general performance improvements than with a limited number of systems, as in reference 5. The stable performance of the technology has been repeatedly demonstrated under a wide range of operational conditions.

The two most indicative signals of interest in light source operation are voltage and bandwidth. Voltage measures efficiency, and bandwidth generally measures the state of halogen gas in the chambers. Bandwidth is also a key optical performance indicator, and chipmakers typically prefer this to be stable and generally low over the long term.

Figure 3 depicts the voltage and bandwidth of a Cymer XLA360 light source as it transitions from pre-GLX to GLX and then to GLX2 operation. This light source was operating at a large memory maker under high utilization, and the data shown is over a period of five months.³ Refills are depicted as vertical lines, and the refill interval can be seen to extend to 1 Bpulses with GLX technology, and to 2 Bpulses with GLX2. The stable long term performance is clear, and the transition from GLX to GLX2 technologies resulted in no unusual transients. The long term drift in the signals is due to other causes (such as module aging), and not to GLX.

Figure 4 shows performance on an XLA165 series laser running at a logic maker, where operation was changed from pre-GLX to GLX and back to pre-GLX. The system was not run for a full 1 Bpulses between refills during GLX operation because of unrelated constraints and anomalies, not due to any GLX limitation. Nonetheless, GLX stability and performance are also good. Additionally, the pre-GLX performance on a lower utilization laser such as this⁴ can show refill transients larger than with GLX (note this particularly in the voltage signal, but also slightly in the bandwidth signal). This is because the intrinsic stability imparted by GLX is also provided to the overall gas state of the chambers, not just the signals of interest, so that refills create less disruption than previous gas control systems can.

Finally, Figure 5 shows the performance of the GLX system versus time instead of pulses, over a period of 5 days at a logic maker (accumulating about 50 Mpulses). During this period, there are long periods where the light source was not used, sometimes for up to half a day, awaiting new processes. The voltage and bandwidth do not show any significant transients, and GLX technology is insensitive to these long pauses, which ensures the light source can be operated in this manner without the need for warm-up. Additionally, Figure 5 shows more detail across a refill, emphasizing again the lack of any transients.

² GLX2™ is a standard feature of Cymer's XLR model light sources

³ The light source was operating at a rate of about 40 Bpulses/year during the period of data shown in Figure 3.

⁴ During the period depicted in Figure 4, the laser was operating at about 4.3 Bpulses/year.

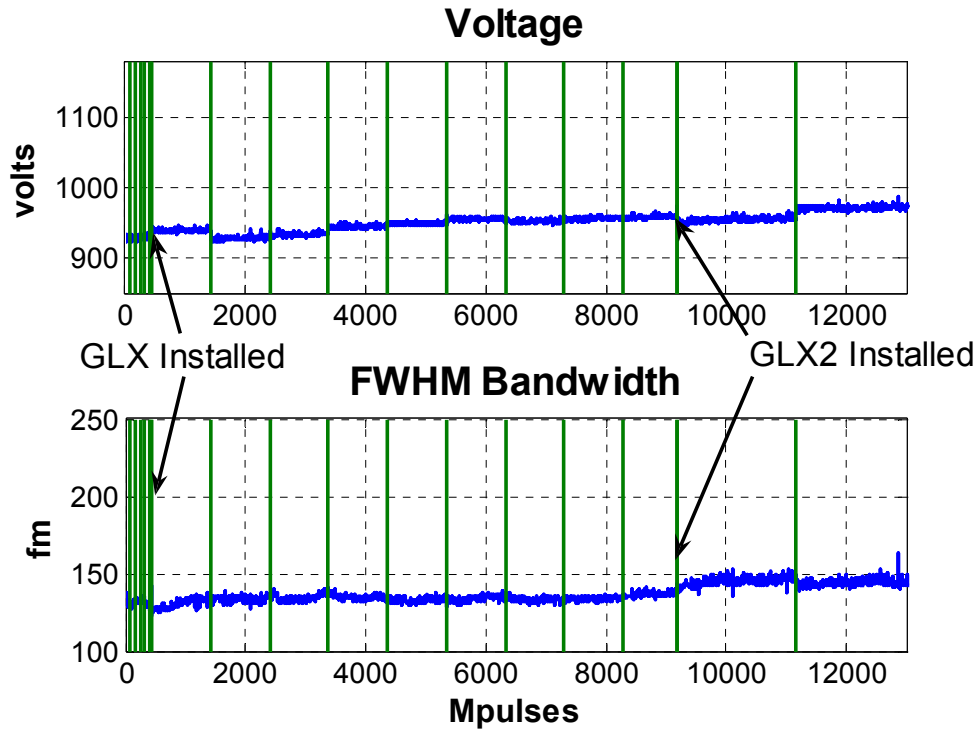

Figure 3. Cymer GLX and GLX2 performance on a high-utilization production XLA laser.

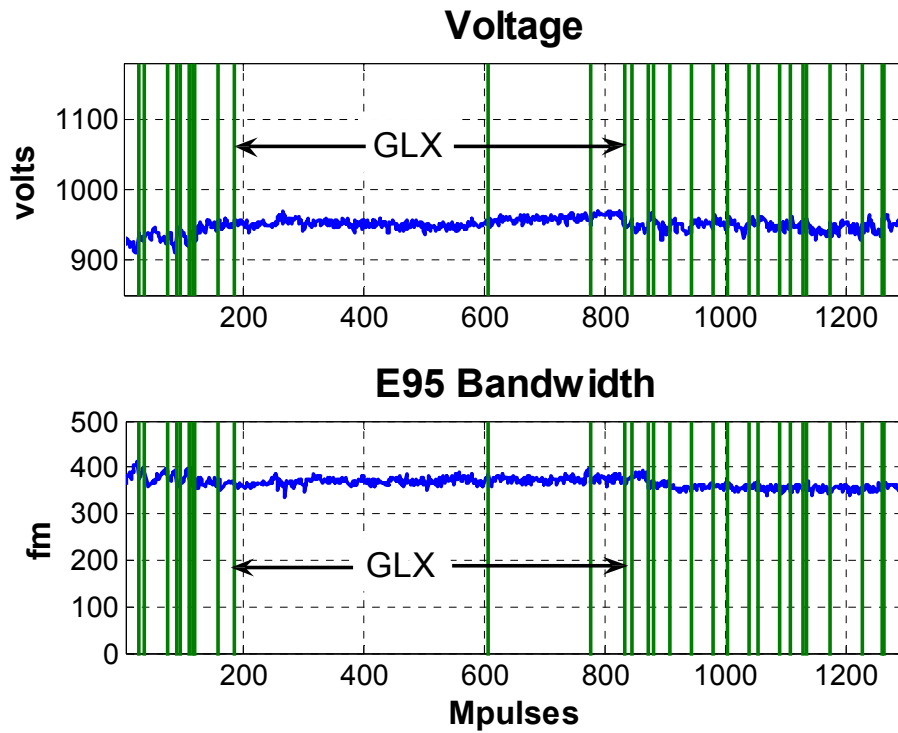

Figure 4. Comparison of GLX and pre-GLX performance on a laser at a logic maker. GLX period is noted.

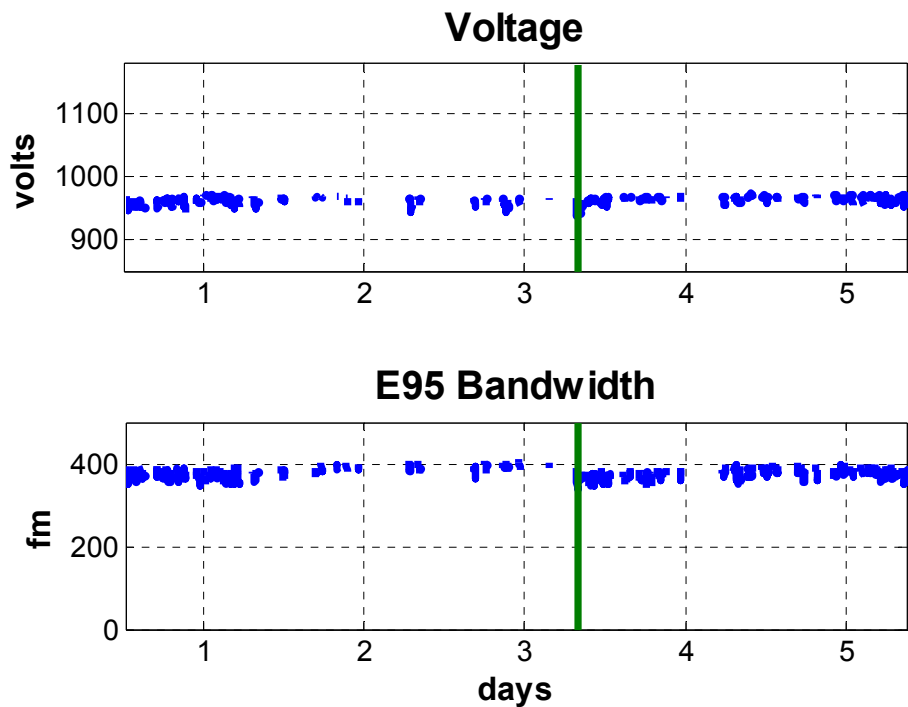

Figure 5. GLX across long pauses and refill.

GLX and GLX2 operate primarily as pulse-based systems, with a time limit well above 30 days for most operational conditions.⁵ The difference between memory or logic makers creates no significant performance differences, either. Therefore, GLX also achieves the goal of supporting all types of lithography systems without specialization or modification. This will allow the productivity improvements to be realized across the industry.

4. GLX™ THROUGHPUT IMPROVEMENT AND DEPLOYMENT

Although the data depicted in Figures 3 through 5 show that performance is not compromised with GLX technology, and it shows individual examples of its reduction in refills, the goal was to provide industry-wide increase in productivity of lithography systems. The improvement is measured most directly by wafer throughput increases. This is a measure of how many additional wafers can be completed over the same period of time.

⁵ The time limit is longer at higher utilizations. For systems with very low utilization, the time limit is no less than 30 days.

Figure 6 shows predicted wafer throughput increase using GLX assuming a reasonable wafer pulse usage, under both ideal and more realistic assumptions of laser usage⁶, as well as data from reports of throughput improvement from actual high utilization users. Ideal laser usage assumes the number of pulses between refills is always at its maximum allowed value. A realistic assumption of laser usage is that a refill is performed about 15 Mpulses *before* the maximum allowed value.⁷ Since the pre-GLX limit is 100 Mpulses, a 15 Mpulse “safety” is effectively a 15% reduction in utilization time, whereas with GLX a 15 Mpulse safety is only 1.5% loss of useful time. This difference is what accounts for the large difference in throughput improvements between ideal and realistic laser usage in Figure 5.

Clearly, the heavier a light source is utilized the more improvement is offered by installing GLX technology. Nonetheless, even very low utilization systems will see a benefit. Additionally, the effective removal of time-based refills allows flexible process improvements that aren’t influenced by light source refill intervals, even for low utilization systems.

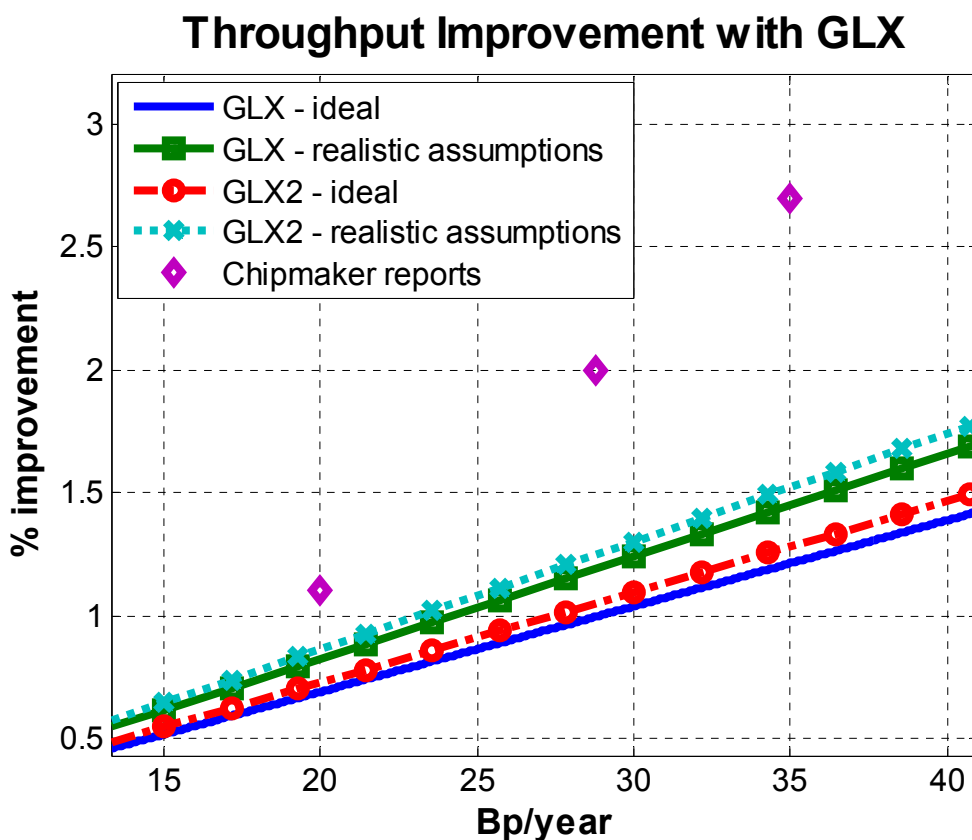

Figure 6. Predicted throughput increase with GLX and GLX2 technology, and actual reported results.⁸

To account for the difference between predicted throughput improvement and actual chipmaker reports, wafer process issues are considered. For example, when a light source is stopped for a gas refill, some processes may require the re-starting of wafers after the stop. Therefore, longer refill intervals reduce process time loss related to the stops. Of course, as the system utilization decreases, this gain will also decrease, which is verified in Figure 6. Also, the difference between the “ideal” and “realistic assumptions” in Figure 6 are based on a “realistic” chipmaker performing a refill 15 Mpulses early. It is not unreasonable that some chipmakers are even more conservative in their scheduling of gas refills, to reduce risk or coincide with other processes, and perform refills much earlier than 15 Mpulses assumed in Figure 6.

⁶ 30 Bp/year represents about 2600 wafer passes/day

⁷ Chipmakers tend to refill early during opportunistic windows, which rarely coincide with the maximum refill interval.

⁸ Chipmaker reports may represent an aggregate over many systems.

The benefits of GLX technology shown above have led chipmakers to rapidly adopt it. Figure 7 shows cumulative installations of GLX and GLX2 throughout 2008. Note that the GLX history may decrease at times because some systems with GLX were replaced by GLX2 installations, starting in July 2008, when GLX2 was initially released. The 200+ systems with GLX or GLX2 installed represents a fraction of all Cymer XLA light sources throughout the world. As much as anything, Figure 7 indicates the effectiveness and value of GLX.

GLX and GLX2 Deployment History

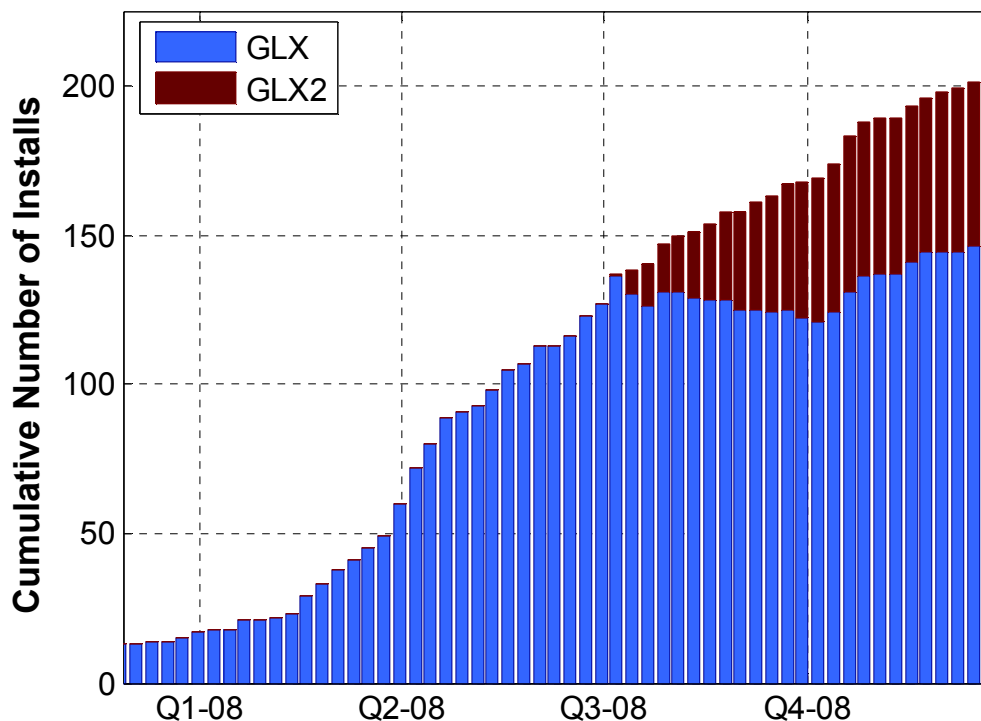

Figure 7. GLX and GLX2 cumulative installations

5. THE CONTINUING FUTURE OF GAS MANAGEMENT

The success of GLX technology illustrates the level to which state-of-the-art technologies and techniques can enhance operational performance and reliability, and implies that further improvements can be made. The results and detailed data analysis of GLX have shown several directions to pursue. Through advanced hardware platforms, more sophisticated algorithms and signal processing, and a deeper understanding of the data that a light source generates, it may be possible to completely eliminate the need for gas refills, while simultaneously reducing gas consumption. Also, as Figure 6 shows, there is a cost-benefit trade-off for systems with lower utilization. Cymer is pursuing avenues that can improve this trade-off, as well.

6. CONCLUSIONS

New means of reducing lithography cell downtime are a constant pursuit of the industry. As demand increases for operational margin, reliability, and high performance, Cymer has continued its aggressive research and development into achieving these goals in its light sources, and led to the technical success of Cymer's Gas Lifetime eXtention™ (GLX™) gas control technology.

GLX's technical success has led directly to its commercial success and has realized productivity gains of up to 2%, even higher than predicted. The rapid adoption of GLX technology worldwide promises to further increase the efficiency of the industry. It also reiterates the value of investments in the sort of research and development that led to GLX, a hallmark of Cymer's history.

Further improvements are currently in progress, and both short-term and long-term gains are anticipated. By continuing along this path, Cymer will maintain its leadership in lithography light source technology.

REFERENCES

1. SEMI E10 – Standard for Definition and Measurement of Equipment Reliability, Availability, and Maintainability
2. S. Skogestad and I. Postlethwaite, "Multivariable Feedback Control." Chichester, U.K.: Wiley, 1996.
3. K. Zhou and J. Doyle, "Essentials of Robust Control". Upper Saddle River, NJ: Prentice-Hall, 1998.
4. Wayne J. Dunstan, Robert Jacques, Kevin O'Brien, Aravind Ratnam, "Increased Availability of Lithography Light Sources using Advanced Gas Management", *Optical Microlithography XX*, Donis G Flagello, Editor, Proceedings of the SPIE, Volume 6520, pp 652032 , 2007.
5. Kevin O'Brien, Wayne J. Dunstan, Daniel Riggs, Aravind Ratnam, Robert Jacques, Herve Besaucele, Daniel Brown, Kevin Zhang, Nigel Farrar, "Performance Demonstration of Significant Availability Improvement in Lithography Light Sources using GLX™ Control System", *Optical Microlithography XXI*, Harry J. Levinson, Mircea V. Dusa, Editors, Proceedings of the SPIE Volume 6924, pp 69242 Q1 – Q9.