

# CD Control Enhancement by LASER bandwidth stabilization for advanced lithography application

R.C Peng<sup>\*a</sup>, Tony Wu<sup>a</sup>, K.W.Chang<sup>a</sup>, C.P.Yeh<sup>a</sup>, H.H.Liu<sup>a</sup>, H.J.Lee<sup>a</sup>, John Lin<sup>a</sup>, Allen Chang<sup>b</sup>, and Benjamin Szu-Min Lin<sup>b</sup>

<sup>a</sup>MTC, Taiwan Semiconductor Manufacturing Corp., Hsinchu Science Park, Hsinchu, Taiwan 300-77, R.O.C.; <sup>b</sup>Cymer Inc., Kuang Fu Rd. HsinChu, Taiwan, R.O.C.

## ABSTRACT

Control of circuit CD in a photolithographic process has become increasingly important, particularly for those advanced nodes below 45nm because it influences device performances greatly. The variation of circuit CD depends on many factors, for example, CD uniformity on reticles, focus, lens aberrations, partial coherence, photoresist performance and LASER spectral bandwidth. In this paper, we focus on LASER spectral bandwidth effects to reduce circuit CD variation. High-volume products of a leading technology node are examined and a novel LASER control function: Gas Lifetime eXtension (GLX) is implemented to obtain stable LASER bandwidth. The LASER bandwidth variation was stabilized by changing laser F2 gas concentration through advanced control algorithm and signal process techniques. Product photo-pattern CD variation and device electrical performances will be examined to confirm the benefits of the LASER bandwidth stabilization.

**Keywords:** CD control, LASER, bandwidth stability, GLX

## 1. INTRODUCTION

As IC circuit critical dimensions (CDs) shrink according to Moore's Law, tighter CD control is required for those advanced nodes below 45 nm by IC manufacturers to precisely produce the designed device electrical properties. DRAM CD control requirements have scaled at about the same rate on ITRS roadmap, but logic gate CD control has scaled much faster, which makes more challenging for logic manufacturers. Many factors may impact the CD control: CD uniformity on reticles, focus, lens aberrations, partial coherence, photoresist performance, and LASER spectral bandwidth. Mask houses, scanner makers, photoresist vendors, LASER light source providers make a lot of efforts every year to catch up the semiconductor industry requests on this tight gate CD control budget. In the past, LASER dose control improvements have scaled at about the same rate as DRAM CD control requirements, however, new LASER technologies are required now to satisfy the much more challenging logic gate CD control requirements.

Based on our past experiences, wider LASER bandwidth reduces imaging contrast and leads to further CD variation as a function of pitch. Optical proximity correction (OPC) is getting more and more difficult to compensate imaging imperfection as the CD shrinks and circuit patterns are getting more complex. OPC on the mask is effective only if imaging contrast is stable. It is why LASER bandwidth stabilization and matching are required to improve CD control. There are several literature papers describing experimental and simulation work on the effects of LASER bandwidth.<sup>[1],[2],[3]</sup> Based on our simulation results, CD shift may be upto 1 nm under a typical LASER bandwidth variation of 100 fm. Tighter LASER bandwidth control is definitely required to achieve the requirements of CD control of leading edge technology nodes beyond 45 nm.

This paper describes the impact of a new LASER technology by Cymer, called Gas Lifetime eXtension (GLX)<sup>[4],[5]</sup>, on logic poly gate CD control in two high-volume products of a leading technology node. Brief explanations on GLX functions and basic working theory are discussed. Product photo-pattern CD (so-called after development inspection CD, ADI CD) variations and device electrical performances are two major indexes to demonstrate the benefits of LASER bandwidth variation by GLX. Detailed product ADI CD variation analysis is also made to decompose the contribution into several improving factors.

## 2. EXPERIMENTAL SETTINGS

A Gas Lifetime eXtension (GLX) system from Cymer was installed into a Cymer 4kHz ArF LASER associated with an ASML XT1700i immersion scanner. No other process or equipment factors were changed to minimize experimental noises. The theory of GLX was reported by K. O'Brien<sup>[5]</sup>. Generally speaking, GLX stabilizes LASER bandwidth long term performance by several technology advancements, including cleaner discharge chambers (which generate fewer contaminants), improved component reliability, new signal processing techniques, and advanced gas control algorithms. Figure 1 illustrates the control paradigm used in Cymer's XLA and XLR series lasers. By combining new signal processing to properly interpret laser signals with advanced control algorithms, GLX computes the precise required amount of halogen ( $\Delta F_2$ ) and buffer gas ( $\Delta ArNe$ ) required for a partial gas replenishment event. Using several enhancements to low level gas handling, GLX very accurately controls the amounts of gas that are replenished. This precise and accurate control enables the state of the chamber gas to be maintained over long periods while maintaining the short term and long term light source performance to specification.

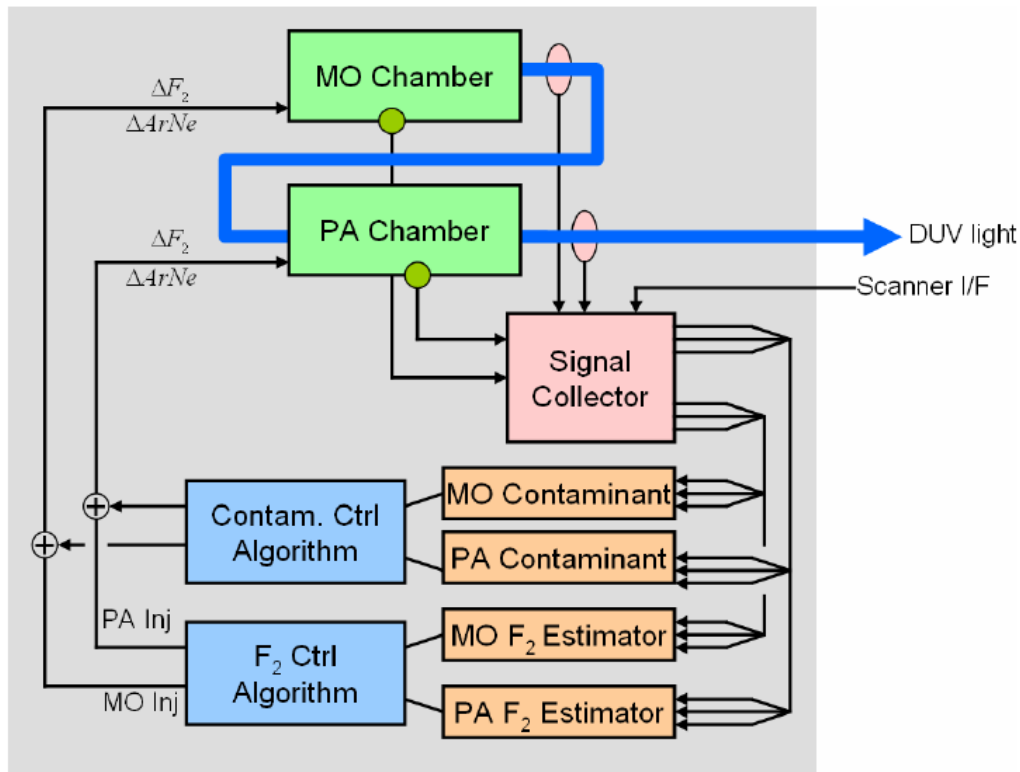

Fig. 1. GLX control system diagram used in Cymer's XLA and XLR series lasers. By combining new signal processing to properly interpret laser signals with advanced control algorithms, GLX computes the precise required amount of halogen ( $\Delta F_2$ ) and buffer gas ( $\Delta ArNe$ ) required for a partial gas replenishment event..

Bandwidth (E95) trend charts within the product wafer exposure period were examined before and after GLX installation to make sure E95 stabilization achieved. E95 data were extracted from the Cymer LASER system log files and Cymer OnLine (COL) system to check the short term and long term E95 stability variations. Two high-volume products of a leading technology node exposed in the GLX installed ASML XT1700i immersion scanner were randomly picked to demonstrate the GLX impacts on product performances of Poly Gate Layer. Product ADI CD values and device electrical data (saturation current,  $I_{sat}$ ) of Poly Gate Layer from these two different products before and after GLX installation were also extracted to describe the improvement in terms of CD variation and device electrical performance variation, respectively. Product ADI CDs were collected from designed in-line CD monitoring patterns by Hitachi 9380-II CD-SEM, and the general sampling rate for full lots (25 wafers per lot) is 3 wafers per lot and 13 CD points per wafer

for each product, however, different sampling rates will be changed due to special requests or non-full lots. Device electrical Isat data were collected from other device electrical test key patterns rather than the previous in-line CD monitoring patterns. The sampling rate of device electrical data collection is different from that of product ADI CD collection.

### 3. RESULTS AND DISCUSSIONS

#### 3.1 E95 Trend Charts

First of all, Cymer LASER parameter trend charts were examined. Figure 2 shows performance on the Cymer 4 kHz XLA series laser running at high-utilization, over a period of more than 2 billion pulses before and after GLX installed. These data were collected from the Cymer LASER system log file for checking real-time pulse bandwidth status. It looks obviously that GLX performance is compared favorably against before-GLX-installed performance. In particular, the before-GLX-installed performance shows variability in voltage and bandwidth due to the frequent gas refills, while GLX performance removes almost all of this by better gas refill control.

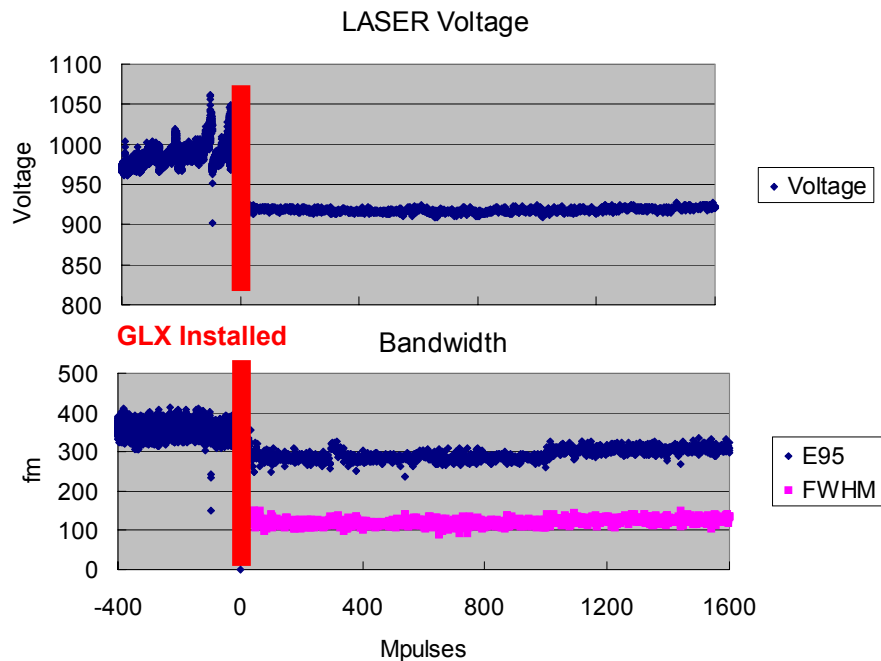

Fig. 2. Real-time LASER parameter trend charts: LASER voltage and bandwidth (FWHM and E95). Red lines indicate the installation of GLX, and GLX extends the gas refill period upto 1 Bpulses and makes more stable in terms of Laser voltage and bandwidth.

Figure 3 demonstrates the Cymer LASER E95 distribution curves during the product wafer exposure periods before and after GLX installed. These E95 data were collected from COL system with a sampling rate of one point every 5 minutes to represent long term E95 stability. The blue curve represents the E95 distribution before GLX installation, while the purple line the E95 distribution after GLX installation. The narrower E95 distribution after GLX installation indicates GLX can induce more stable E95 variation. The root cause of right shoulder of the E95 distribution after GLX installation is not clear but under investigation. Both Figure 2 and Figure 3 indicate GLX impacts on E95 stability significantly for either short term or long term based on different sampling ways.

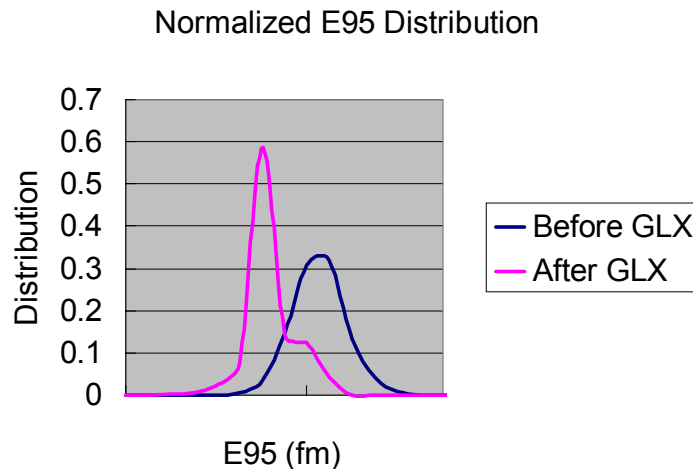

Fig. 3. Normalized COL E95 Distributions before and after GLX installation. The blue curve presents the E95 distribution before GLX installation, while the purple line the E95 distribution after GLX installation.

### 3.2 Product ADI CD Distributions

Two high-volume products exposed in the GLX installed ASML scanner were randomly chosen to examine the product ADI CD variations. Figure 4 shows the ADI CD variations of Product A and B. The blue bars represent the ADI CD 3 sigma values of Product A and B before GLX installation, while the purple bars the ADI CD 3 sigma values of Product A and B after GLX installation. It is obvious that Product B has larger improvement than Product A in term of ADI CD 3 sigma. Since CD variation of Product A has been controlled within a small CD range before GLX installed, the improvement by E95 stabilization may not be as significant as Product B. However, the product-to-product CD variation improves after GLX installation shown in Figure 4, which should be induced by the narrower long term E95 distribution after GLX installation shown in Figure 3.

Normalized product A ADI CD distribution curves before and after GLX installed were shown in Figure 5. These two curves almost match to each other since their ADI CD 3 sigma values are close. Only footings of these two curves differ a little from each other. The peak of after-GLX-installed curve is slightly higher than that of before-GLX-installed one. These can also explain the similar Product ADI CD variation in term of 3 sigma and just a little improvement for that after GLX installation.

The Product ADI CD distribution can be separated into several items: within wafer CD variation, within lot CD variation, and lot-to-lot CD variation. Each of these variations can be expressed as an average value plus a standard deviation value. For example, within lot CD variation can be expressed as within lot CD average plus within lot CD standard deviation. Figure 6 shows the CD trend charts of within wafer CD average, within lot CD average, within wafer CD standard deviation and within lot standard deviation for Product A ADI CD. Purple squares and yellow triangles are within wafer and within lot CD averages, while dark blue diamonds and blue squares are within wafer and within lot CD standard deviations. Lot-to-lot CD variation (range of yellow triangles in Figure 6) converges obviously after GLX installation, which is also shown as the improvement of Lot Average range in Figure 7. The range of wafer CD average is the 2<sup>nd</sup> largest improved item as shown in Figure 7. Since there were only few lots collected ADI CD after GLX installed compared to the lot number before GLX installed, it is suggested to collect more CD data after GLX installed to clarify the improvement of wafer-to-wafer and lot-to-lot CD average ranges. Long term stability of GLX function helps the lot-to-lot CD variation for Product A.

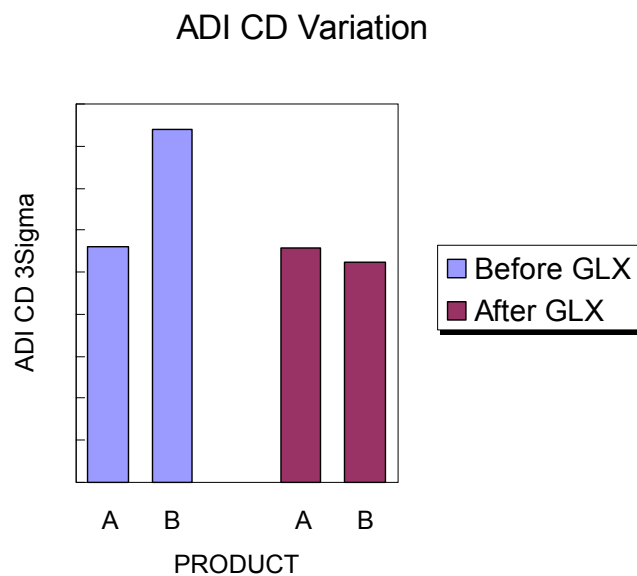

Fig. 4. Product ADI CD variations of Product A and B. The blue bars represent the ADI CD 3 sigma values of Product A and B before GLX installation, while the purple bars the ADI CD 3 sigma values of Product A and B after GLX installation.

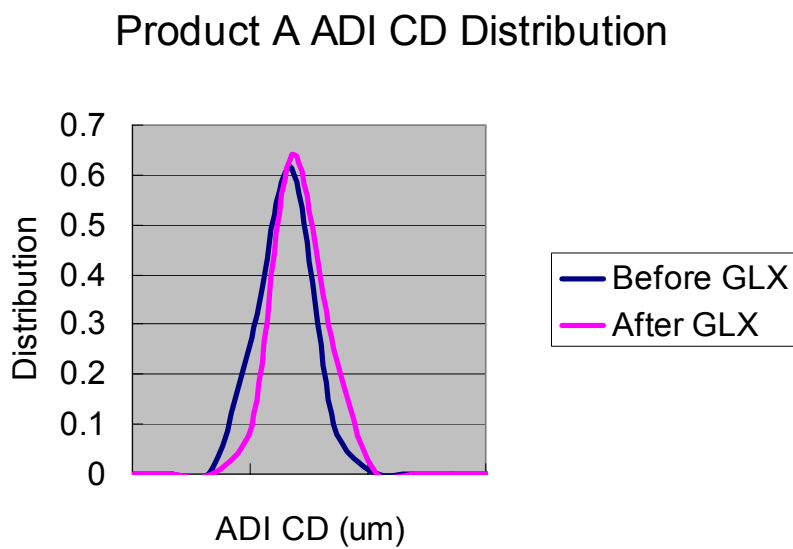

Fig. 5. Normalized Product A ADI CD Distribution.

## Product A ADI CD TREND CHART

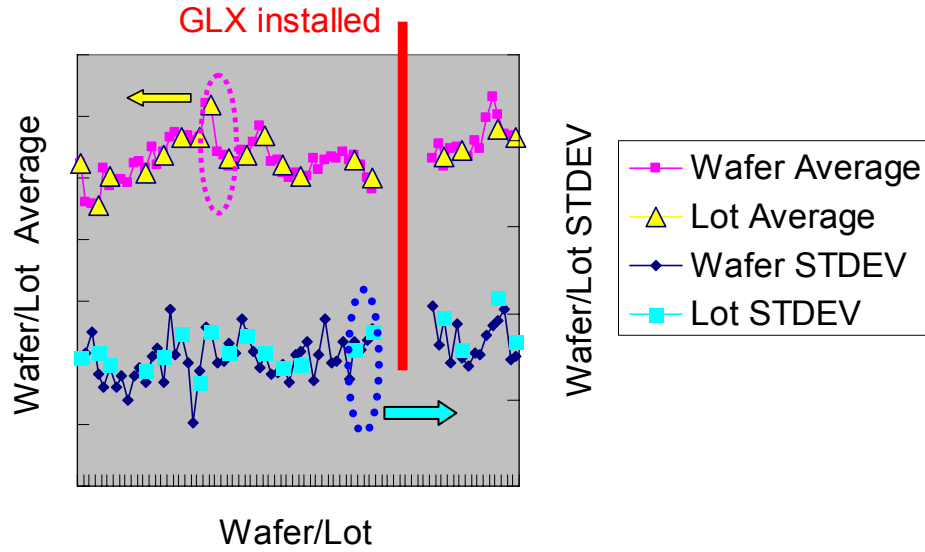

Fig. 6. CD trend charts within wafer and within lot CD average and standard deviations for Product A. Purple squares and yellow triangles are within wafer and within lot CD average, while dark blue diamonds and blue squares are within wafer and within lot CD standard deviations

## Product A ADI CD Range

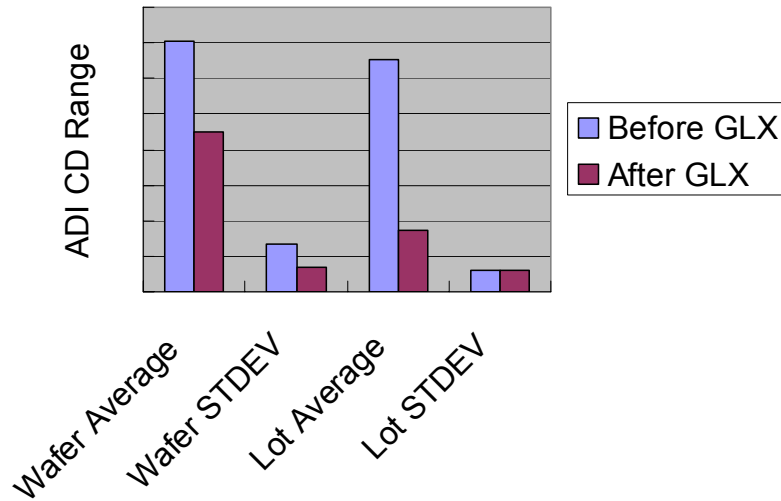

Fig. 7. Product A ADI CD Range for wafer average, wafer standard deviation, lot average, and lot standard deviation. The blue bars represent the Product A ADI CD range values before GLX installation, while the purple bars the Product A ADI CD range values after GLX installation.

Greater improvement in ADI CD variation for Product B than that of Product A was found in Figure 4. Normalized product B ADI CD distribution curves were shown in Figure 8. The ADI CD distribution curve after GLX installed was obviously narrower than that of before GLX installed. The peak of after-GLX-installed curve is higher than that of before-GLX-installed one, and the footing of after-GLX-installed curve is also distributed more tightly than that of before-GLX-installed one. These can well explain the better Product ADI CD variation in term of 3 sigma and a greater improvement for that after GLX installation.

### Product B ADI CD Distribution

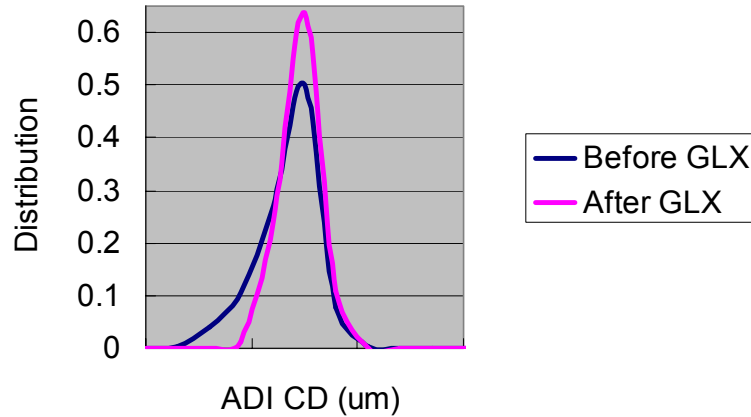

Fig. 8. Normalized Product B ADI CD Distribution.

### Product B ADI CD Range

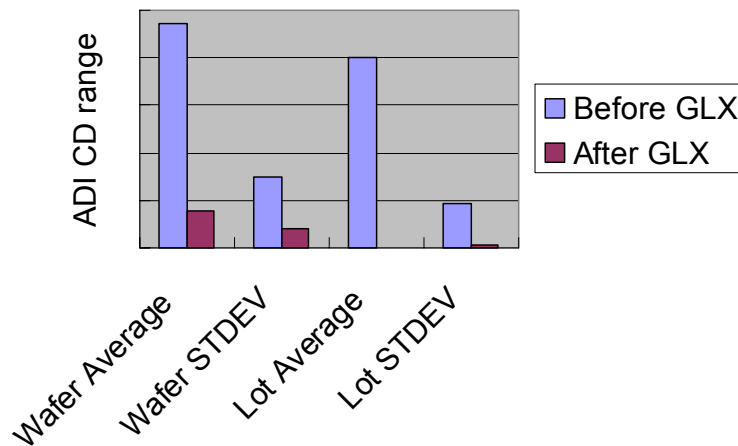

Fig. 9. Product B ADI CD Distribution for wafer average, wafer standard deviation, lot average, and lot standard deviation. The blue bars represent the Product B ADI CD range values before GLX installation, while the purple bars the Product B ADI CD range values after GLX installation.

The Product ADI CD distribution can be separated into several items: within wafer CD variation, within lot CD variation, and lot-to-lot CD variation. Figure 6 shows the CD trend charts of within wafer CD average, within lot CD average, within wafer CD standard deviation and within lot standard deviation for Product A ADI CD. Purple squares and yellow triangles are within wafer and within lot CD averages, while dark blue diamonds and blue squares are within wafer and within lot CD standard deviations. Lot-to-lot CD variation (range of yellow triangles in Figure 6) converges obviously after GLX installation, which is also shown as the improvement of Lot Average range in Figure 7. The range of wafer CD average is the 2<sup>nd</sup> largest improved item as shown in Figure 7. Since there were only few lots collected ADI CD after GLX installed compared to the lot number before GLX installed, it is suggested to collect more CD data after GLX installed to clarify the improvement of wafer-to-wafer and lot-to-lot CD average ranges. Long term stability of GLX function helps the lot-to-lot CD variation for Product A.

### 3.3 Product Device electrical Data (Saturation Current, Isat) Variations

Device electrical data, saturation current (Isat), of Product B were collected as the index to determine the degree of improvement by E95 stabilization. Figure 10 shows the Isat 3 sigma values of 4 devices on Product B before and after GLX installation. Purple bars show the Isat 3 sigma values before GLX installed while blue bars Isat 3 sigma values before GLX installed. Orange triangles show the improvement percentages of Isat by GLX. Three out of four devices have improvement in term of Isat 3 sigma from 8% to 19%, but the Isat 3 sigma of Device 4 degrades by 3%. Different device electrical test key patterns may be one of factors which produced different percentages of Isat for every device, though E95 stabilization has been achieved by GLX. However, the average Isat improvement percentage over these four devices is around 9% for Product B.

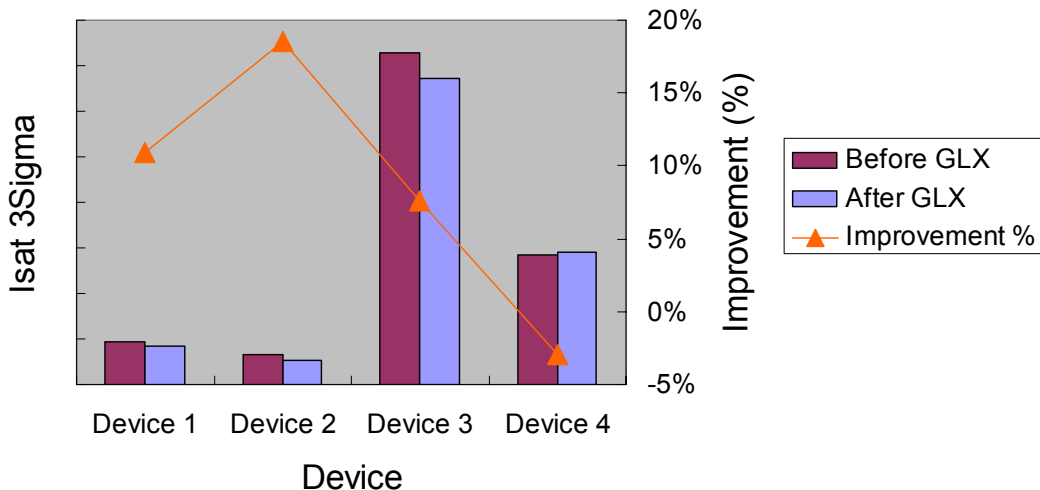

Fig. 10. Isat 3 sigma values of 4 devices on Product B before and after GLX installation. Purple bars show the Isat 3 sigma values before GLX installed while blue bars Isat 3 sigma values before GLX installed. Orange triangles show the improvement percentages of Isat by GLX.

## 4. CONCLUSION

In this paper, stabilizing LASER bandwidth by Gas Lifetime eXtension (GLX) function can improve product ADI CD variations and device electrical performances of Poly Gate Layer of a leading technology node. Long term bandwidth stability was then achieved by GLX features including cleaner LASER discharge chambers, improved LASER component reliability, new signal processing techniques, and advanced gas control algorithms. Narrower product ADI CD distribution was demonstrated as the LASER E95 distribution getting improved after GLX installation. Lot-to-lot CD variations for both products have been improved significantly, which indicated the benefit of long term bandwidth

stability by GLX. Device electrical performances, saturation current (Isat) also had same improvement like product ADI CD variations. Average Isat improvement of 9% was obtained for those chosen devices in this work.

## 5. ACKNOWLEDGEMENT

Authors want to express our special thanks to the Field Service Team, Cymer Southeast Asia Ltd., for helping Cymer LASER parameter extraction.

## REFERENCES

- [1] Kroyan, A., Farrar, N., Bendik, J., Semprez, O., Rowan, C., Mack, C. A., "Modeling the Effects of Excimer Laser Bandwidths on Lithographic Performance", Proc. SPIE 4000, 658 (2000).
- [2] Kroyan, A., Lalovic, I., Farrar, N., "Effects of 95% Integral vs. FWHM Bandwidth Specifications on Lithographic Imaging", Proc. SPIE 4346, 1244 (2001).
- [3] Huggins, K., Tsuyoshi, T., Ong, M., Rafac, R., Treadway, C., Choudhary, D., Kudo, T., Hirukawa, S., Renwick, S. P., and Farrar, N., "Effects of Laser Bandwidth on OPE in a modern lithography tool", Proc. SPIE 6154, 61540Z (2006).
- [4] Dunstan, W. J., Jacques, R., O'Brien, K., Ratnam, A., "Increased Availability of Lithography Light Sources using Advanced Gas Management", Proc. SPIE 6520, 652032 (2007)
- [5] O'Brien, K., Dunstan, W. J., Riggs, D., Ratnam, A., Jacques, R., Besaucele, H., Brown, D., Zhang, K., Farrar, N., "Performance Demonstration of Significant Availability Improvement in Lithography Light Sources using GLX™ Control System", Proc. SPIE 6924, 69242Q (2008)