

# Increased Availability of Lithography Light Sources using Advanced Gas Management

Wayne J. Dunstan<sup>1</sup>, Robert Jacques, Kevin O'Brien, Aravind Ratnam  
Cymer Inc., 17075 Thornmint Court, San Diego, CA, 92127, USA

## ABSTRACT

Increasing throughput demands on leading edge scanners are requiring greatly improved light source availability. This translates directly to minimizing *downtime* and maximizing *productive time*, as defined in the SEMI E10 standard. One positive contributor to improving productive time is the minimization of the light source stoppage for entire Halogen gas replenishment. This paper describes availability improvements of Cymer XLA and 7000 series light sources by using advanced gas management schemes to minimize entire gas replenishment impact to productive time. Recent augmented gas control algorithms have demonstrated multiple times extension of gas life through advanced gas replenishment methods and higher performance estimators. Along with these improvements to gas management, major efforts in light source fault reduction, module lifetime extension and optimization of module replacement, will provide significantly increased combined light source\scanner availability.

**Keywords:** laser, availability, gas, management, control

## 1. INTRODUCTION

As throughput demands increase on leading edge scanners, a greater focus on minimizing downtime and maximizing productive time becomes essential. In the past, cutting edge light sources have focused primarily on delivering the high performance requirements demanded by the lithographic process. However light source manufacturers have an increasing responsibility to ensure that the light source delivers improved availability as the product matures.

The SEMI E10 standard defines downtime to include preventative maintenance and replacement of consumables, such as light source chambers and optics. Figure 1 illustrates the SEMI E10 standard, named, *Specification for Definition and Measurement of Equipment Reliability, Availability, and Maintainability*. The two blue downtime boxes denote the total time lost (downtime) due to module replacement, while the green standby box indicates non-productive manufacturing time that includes Halogen gas refills.

Cymer has committed considerable effort to ensuring a positive trend to the light source availability is maintained. This has included reduced times for replacement of end-of-lifetime modules and longer module lifetimes allowing larger periods of productive time before a module replacement is required. Procedural changes such as synchronized module exchanges, whereby modules of similar age are exchanged simultaneously, have also decreased overall *equipment downtime*. The combination of these efforts have improved the overall availability by 0.2%.

---

<sup>1</sup> [wdunstan@cymer.com](mailto:wdunstan@cymer.com) phone: int+1-858-385 6177, [www.cymer.com](http://www.cymer.com)

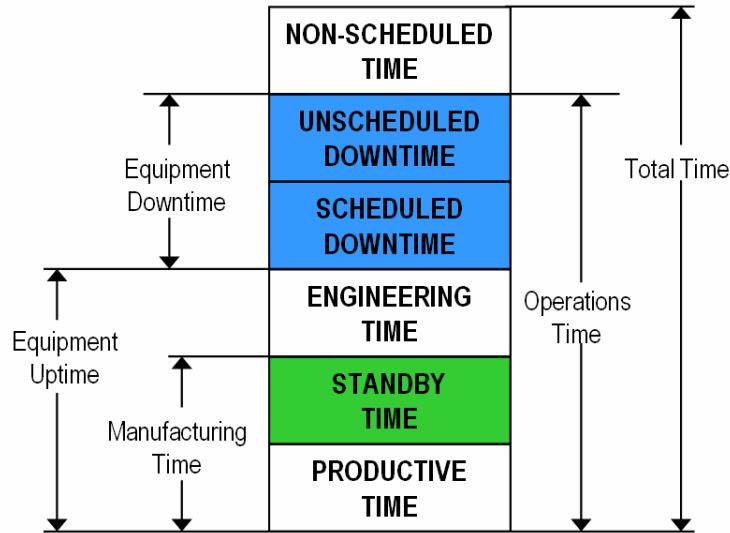

Figure 1: Breakdown of SEMI E10 standard.

Cymer has determined a positive contributor to reducing standby time and thereby increasing productive time is the minimization of the light source stoppage for Halogen gas replenishment. To date, interrupting the scanner operation to allow for Halogen gas replenishment of the light source has been an unavoidable necessity. However with better gas control algorithms, fewer Halogen gas replenishments, which require the laser to stop discharging, may be needed, leading to appreciable gains in productive time.

This paper describes some of the developments in advanced gas management schemes that aim to minimize gas replenishment impact to productive time. These schemes could be utilized on Cymer XLA and ELS laser platforms.

## 2. GAS MANAGEMENT

Cymer XLA and 7000 series lasers employ one or more Halogen gas filled chambers as the gain medium. As the light source operates, the Halogen gas is depleted and contaminants accumulate, so the gas must be periodically replenished.

The Halogen gas consists of either Ar or Kr depending on the desired laser wavelength, along with Ne and F<sub>2</sub>. As the light source discharges energy across its electrodes to generate Deep Ultra-Violet (DUV) light, some of the fluorine atoms may be temporarily disassociated and temporarily form dimers of ArF or KrF. They may then recombine with other compounds (e.g. metals) inside the light source chamber and possibly form solid particles that accumulate as debris within the chamber. This debris has two negative effects: (1) it reduces the amount of fluorine available for use as a dielectric between the electrodes and (2) it acts as contaminant decreasing the light source efficiency.

Other contaminants may also be present in the chamber gas including carbon compounds, atmospheric gases, and combinations of these molecules with fluorine. These compounds can manifest over time causing a decrease in the laser efficiency seen as an increase in discharge voltage required to create a constant pulse energy. The discharge voltage has an upper limit and so action must be taken remove contaminants and replenish the lost fluorine, typically in the form of a gas replenishment.

This can be a partial replenishment while the light source continues to operate, called an inject, that is subject to constraints to ensure the light properties remain within specifications. Alternatively, it may be a full replenishment, called a refill, where all of the chamber gas is replaced while the laser is not firing. Refills are to be minimized because of the large disruption they introduce to both the light source and scanner operation.

During a refill replenishment almost all of the Halogen is vacuum pumped from the chamber, including most of the contaminants produced during the previous gas life. Fresh Halogen gas is introduced to the chamber, and the laser efficiency returns almost entirely back to its baseline. However a drawback of exchanging the entire chamber of gas is evident in Figure 2

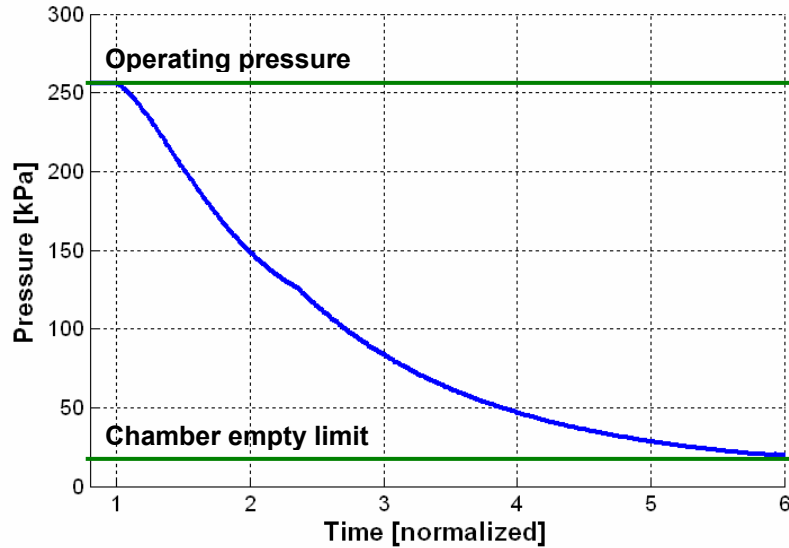

Figure 2: Pressure during chamber evacuation.

The Halogen gas pressure decreases as an inverse exponential with time, so the time to remove any given quantity of gas increases with time.

One promising method for decreasing replenishment time is by performing only *partial refills*. Exchanging a fraction of the entire chamber's gas each time gives the benefit of significant contaminant removal, while reducing considerably the stoppage time of the light source and associated downtime. In fact, if certain laser performance parameters can be kept in specification during the partial refill, then there is no need to stop the light source, and hence there is no downtime.

However partial refills do leave some level of contaminants remaining in the chamber, higher than a complete refill, so they must occur frequently enough to avoid unacceptable voltage rise via the associated efficiency loss.

By utilizing advanced control algorithms that trigger injects, partial refills and complete refills, it is believed that the overall light source downtime could be reduced significantly.

### 3. GAS CONTROL ALGORITHMS

Traditionally the primary purpose of the gas control algorithm was to provide baseline stability of the Halogen gas concentration inside the discharge chamber. This was important as the Halogen gas concentration affects laser performance parameters, including bandwidth, discharge voltage efficiency and energy stability. Figure 3 shows how  $E_{95}$  bandwidth of light exiting the laser varies as Halogen Gas ( $F_2$  /ArNe) concentration is adjusted in the MO chamber on a typical MOPA configuration. The MO chamber response in the Cymer XLA platform (MOPA system) is similar to the single chamber response of a Cymer ELS-7010 platform.

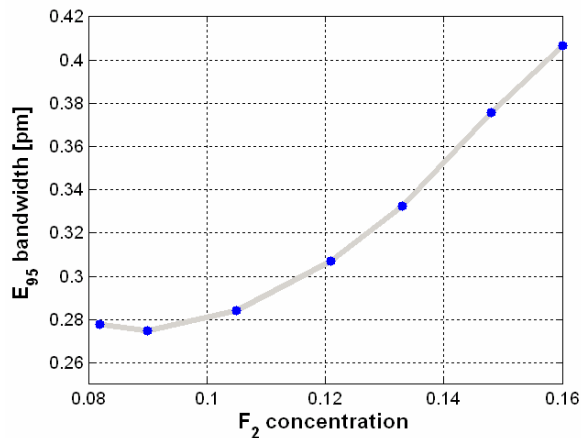

Figure 3: E<sub>95</sub> bandwidth variation for various F<sub>2</sub> concentrations

While a laser is firing, fluorine is depleted as described in Section 2, and current generation gas control algorithms regulate the rate and size of fluorine injected into the chamber such that certain baseline characteristics (bandwidth, discharge voltage efficiency and energy stability) all remain within specification.

Figure 4 illustrates the current generation control algorithm. A set of laser signals including, voltage, MO and PA energy, voltage discharge efficiency, differential commutation time between the MO and PA, E<sub>95</sub> bandwidth, pulse duty cycle and MO and PA chamber pressure and temperature signals are routed through a signal processor and into two estimators to predict the F<sub>2</sub> concentration of the MO and PA chambers. The change in F<sub>2</sub> concentration information is fed into a control algorithm that determines the rate and size of F<sub>2</sub> / ArNe injects into the MO and PA chambers to restore the proper F<sub>2</sub> concentration, such that key laser baseline performance characteristics remain within specification.

The stabilization of these baseline characteristics allows other laser control algorithms and actuators to optimize the performance of a particular laser attribute. For example, E<sub>95</sub> bandwidth can be regulated using other actuators once the baseline stability is reached using the gas control algorithm (refer paper last year).

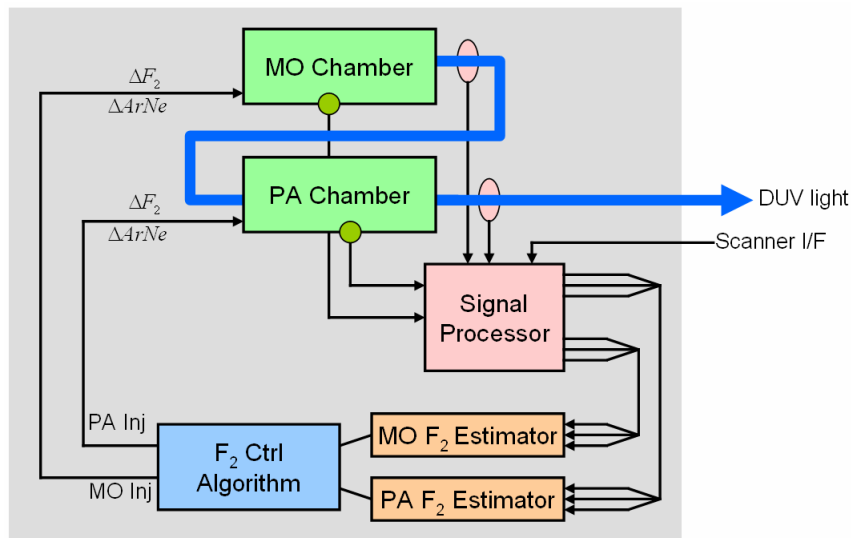

Figure 4: F<sub>2</sub> control algorithm block diagram for XLA series light source.

However current generation gas control algorithms are only able to keep the Halogen gas concentration fixed, and hence the baseline characteristics stable, for a finite period until the accumulated contaminant levels can only be ameliorated

by a refill. Without any addition of contaminant suppressing technology, the  $F_2$  concentration control algorithm reacts to the increasing contamination as though it were a decrease in  $F_2$  concentration. Essentially the  $F_2$  estimators cannot observe the difference between rising contaminant levels and falling  $F_2$  concentration levels.

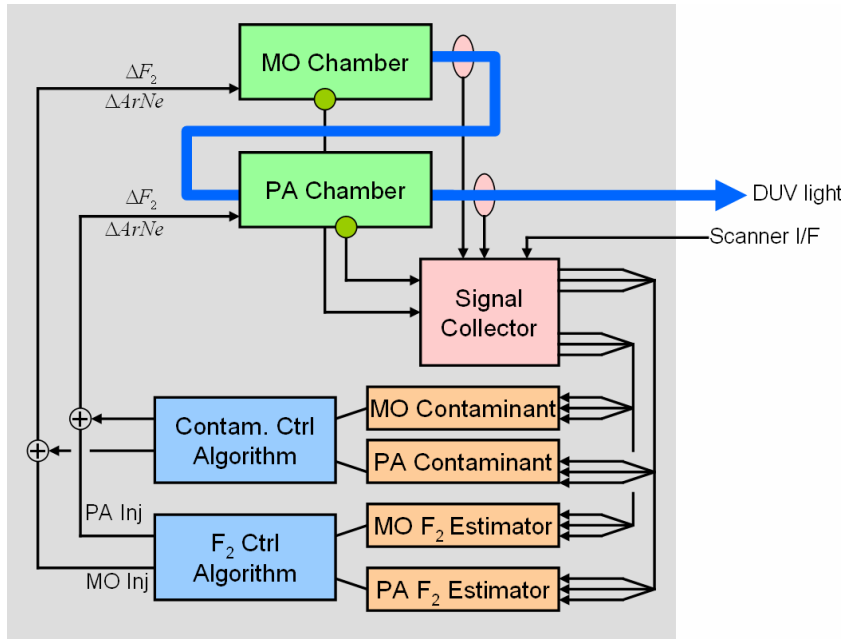

Figure 5: Latest generation combined  $F_2$  control and contaminant control algorithm block diagram for XLA series light source.

Cymer has developed control algorithms that employ both baseline  $F_2$  concentration stabilization and partial refill technology, that allow the laser to keep firing while maintaining performance parameters within specification, to achieve significantly increased gas life capability.

Figure 5 illustrates the combination controller block diagram. The key is the parallelization of the existing  $F_2$  concentration control algorithm and the newly architected contamination control algorithm. These two control algorithms work in tandem to achieve the overall objective of very long light source operation before the need for an entire Halogen gas replenishment.

Two additional estimators are needed to estimate the level of chamber contamination using onboard laser signals. These contaminant estimates are then utilized by the contaminant control algorithm to initiate distributed partial refills. By distributing the partial refills into tightly bounded increments, the algorithm provides the level of contaminant removal required for continuous operation, whilst simultaneously satisfying the constraints required to keep laser baseline performance characteristics within specification.

These advanced control algorithms employing contaminant mitigation are only now becoming viable because of significant reductions in contaminant sources. Improved chamber contamination avoidance and cleaner chamber build procedures have enabled the opportunity to utilize these new gas control algorithms, resulting in very long gas lives before a complete chamber refill is required.

Figures 6, 7 and 8 show the commanded voltage, E95 bandwidth and efficiency of a Cymer XLA100 platform. Notice the negligible voltage rise over a period of 1 billion shots, while changing the laser duty cycle to various values, changing the target energy and all without any additional chamber refills. Indeed the gas showed little or no signs of aging, even at 1Bpulses. (The downward spike after 800Mshots is due to a pause and subsequent restart in light source discharging.)

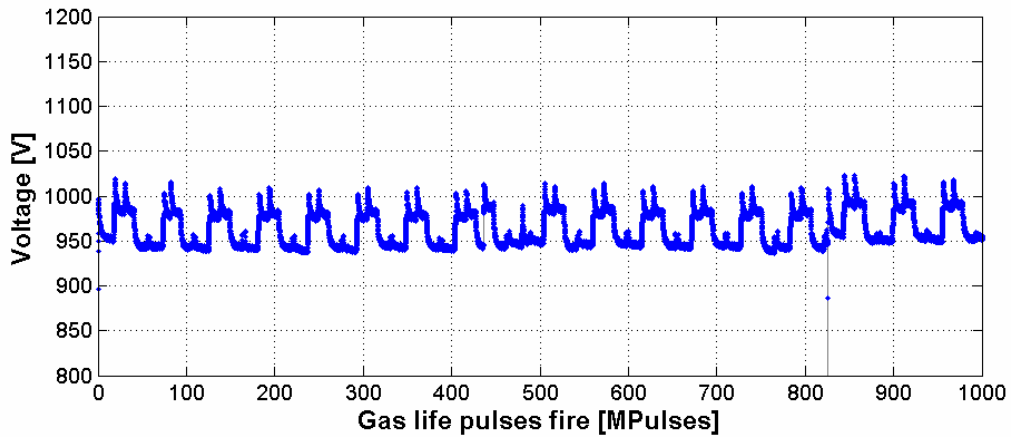

Figure 6: Voltage during a 1Bpulse gas life.

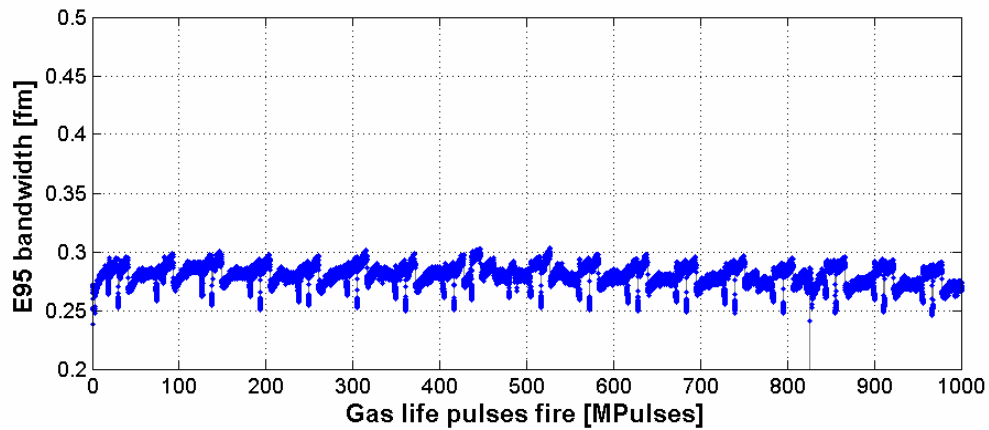

Figure 7: E95 bandwidth during a 1Bpulse gas life.

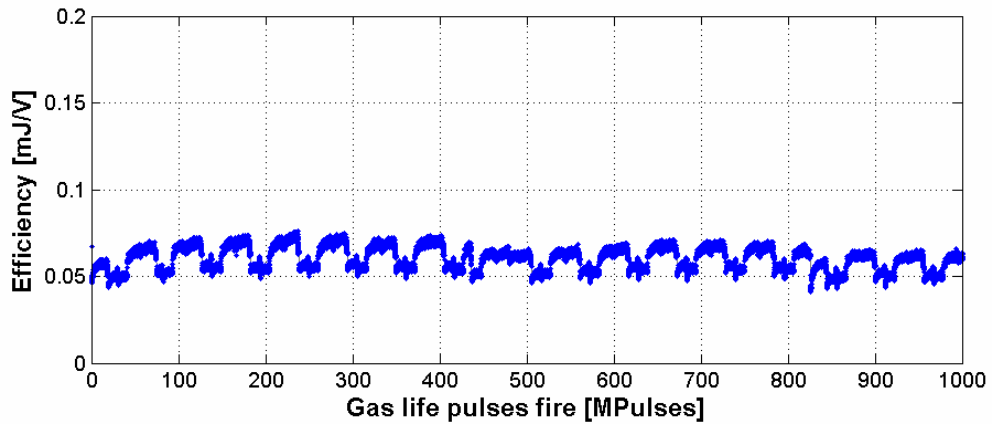

Figure 8: Efficiency during a 1Bpulse gas life.

These plots illustrate the gas lifetime extension possibilities using the new gas control algorithms available from tighter process control requirements and a deeper understanding of light source dynamics.

#### 4. GAS LIFETIME PREDICTION

The need for refills, as discussed previously, requires the light source to stop discharging light. When this happens, the lithographic process must be halted in a controlled manner to prevent reworking of the in-process wafers. This control is achieved by coordinating refills with the scanner. However, the need for a refill can depend on several complex and often unpredictable variables (light source firing pattern, light source energy, age of light source modules, etc.). Therefore, coordination of refills with the scanner is done by a regular schedule, which ensures that the light source operation will never suffer unanticipated interruption due to the light source reaching some operational limit.

This schedule often yields very conservative upper limits on the time between refills. That is, if some users of the light source operate at low pulse usages, the actual time between a required refill could be much greater than the simple schedule permits.

Cymer has developed technology that more accurately predicts the need for a refill, to reduce this conservatism, and deliver longer gas lives on average. This gas lifetime prediction makes use of the deep understanding of light source operation gained through years of experience, along with novel algorithms and signals derived from the light source.

Combining knowledge of (a) the rate at which optical modules age, (b) the rate at which fluorine is depleted and (c) the parameters that affect these rates, we are able to construct dynamic models that can be used to predict the gas lifetime for a specific light source. Calibrating these models with the history of operational parameters since the start of the gas life allows us to predict the performance for some period into the future, given specific measurements from the laser.

Figure 9 shows an example of how the predictor operates. The x-axis shows the current number of shots accumulated on the gas life. The y-axis is the predicted number shots remaining on this gas life before a refill is required. As an analogy, the x-axis can be thought of as an odometer in a vehicle, and the y-axis as the distance-to-empty indicator.

Initially, between the refill and approximately 300Mshots, the predictor gathers light source performance data and filters it through a dynamic model of the process. As the model confidence in the length of the gas life increases, the predicted number of remaining shots increases. Eventually, the number of remaining shots begins to decrease as the gas life progresses, until the actual end of the gas life is reached. At this point, the predictor successfully indicates that the light source can no longer meet performance specification requirements, and that a refill is necessary. Under the simple schedule, with a forced refill at 300Mshots, the gas life would have been arbitrarily and prematurely ended.

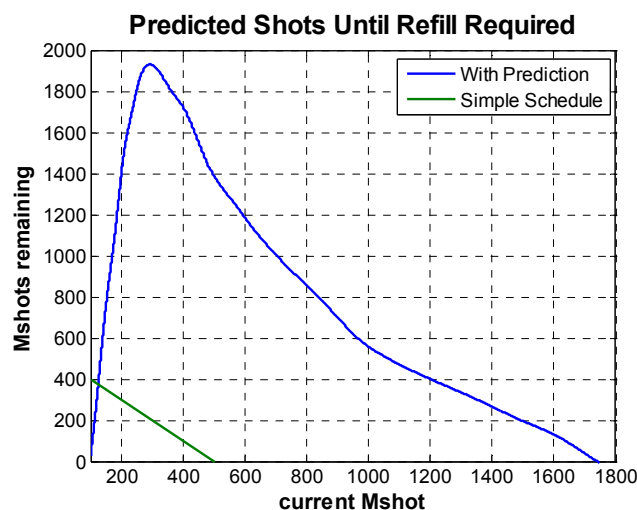

Figure 9: Prediction of remaining shots in a gas life, comparison using advanced prediction and simple schedule.

The effectiveness of the prediction depends upon the model accuracy and the confidence derived therein. The model accuracy in turn is partially dependent upon how the light source is operated and how significant other unmodeled

dynamics are. However, when coupled with the gas life extension algorithms discussed in the previous sections, such variability become less significant to the prediction, thus increasing the predictors accuracy over a multitude of operating regimes.

## 5. CONCLUSIONS

As throughput demands on leading edge scanners increases, improved light source availability will be required, necessitating methods that reduce downtime and standby time.

To meet these needs, Cymer has developed designs for longer life modules and best practices for rapid module exchange to ensure minimal impact to the availability budget. Complementing this effort, Cymer has created advanced control algorithms that maximize halogen gas lifetime before a complete refill is required, thus minimizing gas replenishment impact to productive time. These algorithms employ a plurality of estimators and controllers operating in synergy to simultaneously regulate F2 concentration and minimize chamber contaminant growth rate, such that very long gas lives in excess of one billion pulses are attained before a refill is required.

Cymer has also demonstrated that by using a variety of derived signals and dynamic models we are now able to predict the end of a gas life and dynamically determine when a refill will be required. Based upon a lithography user's pulse utilization patterns this may enable longer gas lifetime between refills, rather than relying on a simple and conservative refill schedule.

Cymer has demonstrated that these methods are suitable for integration into their light source product range and will allow longer gas lives, resulting in less impact to the lithography tool productive time.

## REFERENCES

1. Wayne Dunstan, Robert Jacques, Robert J. Rafac, Rajasekhar Rao, Fedor Trinchouk, "Active Spectral Control of DUV light sources for OPE minimization", *Optical Microlithography XIX*, Donis G Flagello, Editor, Proceedings of the SPIE, Volume 6154, pp. 850-858, 2006.
2. SEMI E10 – Standard for Definition and Measurement of Equipment Reliability, Availability, and Maintainability
3. S. Skogestad and I. Postlethwaite, "Multivariable Feedback Control." Chichester, U.K.: Wiley, 1996.
4. K. Zhou and J. Doyle, "Essentials of Robust Control". Upper Saddle River, NJ: Prentice-Hall, 1998.